

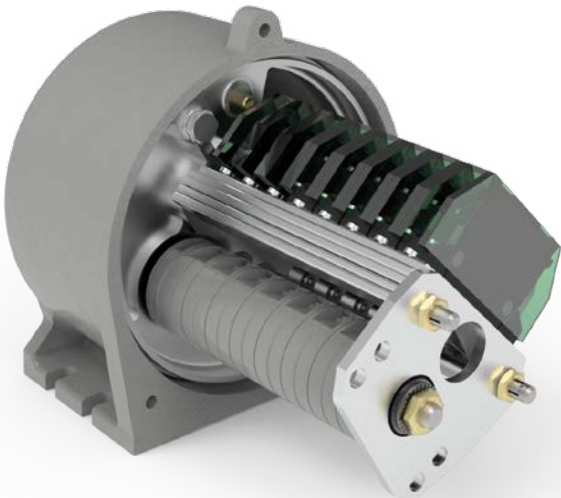

SERIES 100 / 110
GEARED CAM LIMIT SWITCHES



Stromag

Founded in 1932, Stromag has grown to become a globally recognized leader in the development and manufacture of innovative power transmission components for industrial drivetrain applications. Stromag engineers utilize the latest design technologies and materials to provide creative, energy-efficient solutions that meet their customer's most challenging requirements.

Stromag's extensive product range includes flexible couplings, disc brakes, limit switches, an array of hydraulically, pneumatically, and electrically actuated brakes, and a complete line of electric, hydraulic and pneumatic clutches.

Stromag engineered solutions improve drivetrain performance in a variety of key markets including energy, off-highway, metals, marine, transportation, printing, textiles, and material handling on applications such as wind turbines, conveyor systems, rolling mills, agriculture and construction machinery, municipal vehicles, forklifts, cranes, presses, deck winches, diesel engines, gensets and stage machinery.



CONTENT

Series 100 / 110: III

At a Glance	4
Series 100/110 – Basic Design	5
Series 100/110 – Gear Data	6
Series 100 – Steel Sheet Housing B3, B3 / B5, B14, B5	7
Series 100 – Cast Iron Housing B3, B3 / B5	11
Series 110 – Polycarbonate Housing B3, B3 / B5	12
Series 100 – Lever Limit Switch	14
Series 100 – Available Levers	15
Series 100 – Lever Limit Switch Steel Sheet Housing	16
Series 100 – Lever Limit Switch Cast Iron Housing	17
Series 100 – Counterweight Limit Switch	18
Series 100 – Counterweight Limit Switch Steel Sheet Housing	19
Series 100 – Counterweight Limit Switch Cast Iron Housing	20
Series 100/110 – Available Switches	21
Series 100/110 – Cam Disc Types	22
Series 100/110 – Option Anti-Condensation-Heating	23
Series 100/110 – Option Drive Flange F, F+M	24
Series 100/110 – Customizable Cam Discs	25
Series 100 – High Temperature & Radioactive Environment	26
Series 100/110 – Key of Types	27
Series 100 – Special Type ATEX	28
Series 100/110 – Encoder Device	29
Series 100/110 – Option: Analog Encoder	30
Series 100/110 – Option: Incremental Encoder	31

Stromag Geared Cam Limit Switches

AT A GLANCE



STROMAG SERIES 100/110

BENEFITS INCLUDE

- Heavy duty housings for rough environments
- Execution for up to 120°C possible
- For nuclear application (on request) too

Series 100 / 110 – Basic Design

Revision number: 3.1.3.1-01

Revision date: 19.11.2019

Features

- Geared Cam Limit Switch in metal or synthetic housing with IP65 and IP66 protective ratings
- High variants of gears available

Application

- Cranes on- and offshore
- Steel works
- Generally for rough environments

Additional information

- Available as geared, lever or counterweight execution
- -40°/-30°C up to +85°C depending on built in switching contacts

Cast iron housing IP66

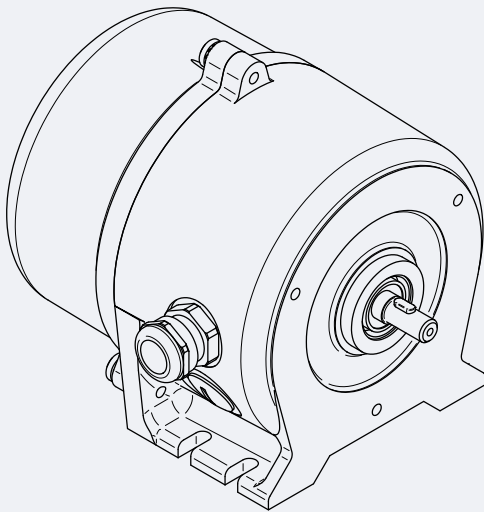

Steel sheet housing IP65

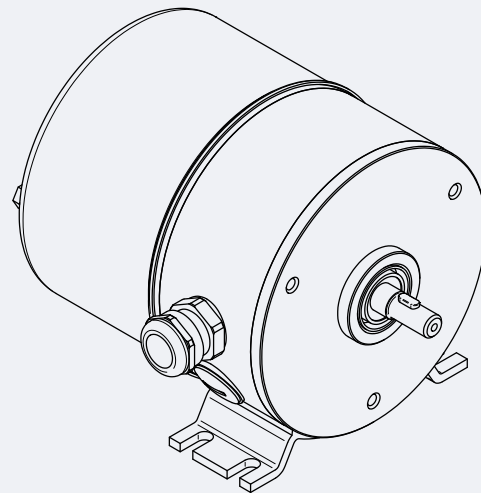

Polycarbonate housing IP66

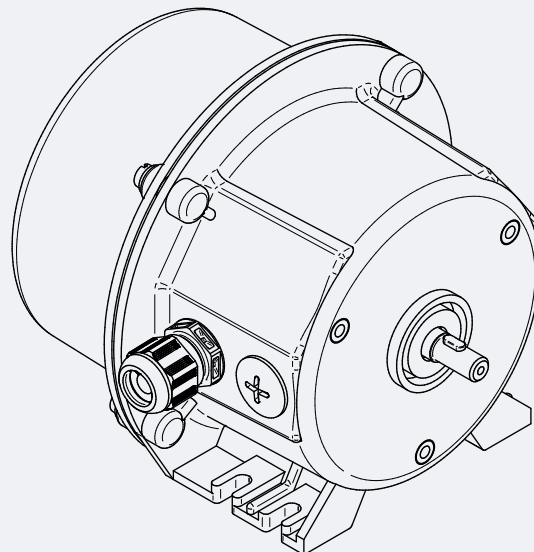

Stromag Geared Cam Limit Switches

Limit Switch Control Current

Series 100 / 110 – Gear Data

Revision number: 3.1.3.2-01

Revision date: 19.11.2019

Features

- Positive form locked connection gear in synthetic or metal execution
- High variants of gear ratios possible, 0,175 up to 17222 restricted by housing size

Application

- Cranes on- and offshore

Additional information

- Pre-tensioned gear wheels for less backlash possible

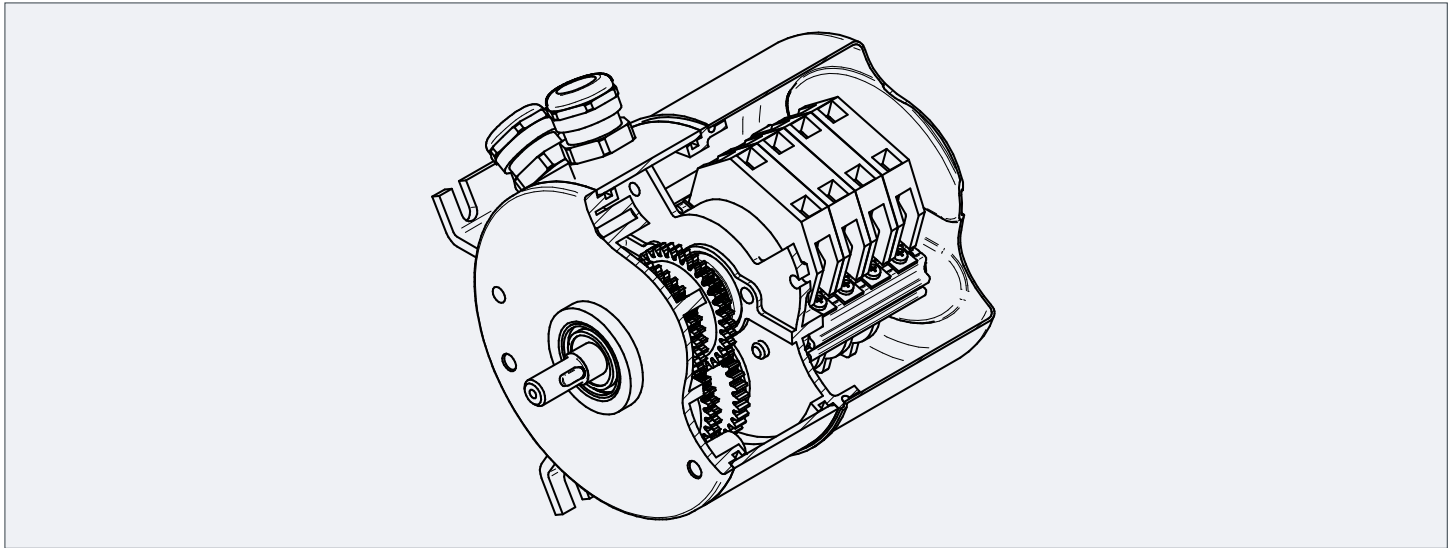

		Gearbox - for contacts 51, 52, 53, 80, 81, 88, 90, 90G with cam discs 40° FV													
		Nominal revolutions	Usable revolutions with 40° cam disc	Gear ratio	Castor revolutions of the drive shaft after each side	Mechanical hysteresis [revolutions at drive shaft]		Max. input speed [rpm]	Min. input speed for alternating operation [rpm]				Min. drive torque for switching an individual contact [Nm]	Max. drive torque for forced opening of an individual contact [Nm]	
						Contact			Contact					Contact	
						51, 52	80, 88, 90, 90G		51, 52	90, 90G	88	80		51, 52, 53	80, 81, 88, 90, 90G
Size	1	0,153	0,152	0,175	0,022	0,001	0,002	50	0,001	0,037	0,007	0,074	1,5	5,368	9,881
		0,45	0,449	0,514	0,066	0,004	0,007	150	0,004	0,109	0,022	0,218	0,5	1,813	3,344
		0,76	0,872	1	0,128	0,008	0,014	150	0,007	0,212	0,042	0,424	0,2	0,875	1,663
		0,91	0,906	1,039	0,133	0,009	0,014	500	0,007	0,22	0,044	0,441	0,2	0,85	1,608
		1,69	1,696	1,944	0,248	0,016	0,027	600	0,014	0,413	0,083	0,825	0,2	0,547	0,952
		5	4,998	5,73	0,732	0,048	0,08	600	0,041	1,216	0,243	2,432	0,2	0,318	0,455
		6,4	6,41	7,352	0,939	0,061	0,102	600	0,052	1,56	0,312	3,12	0,2	0,292	0,399
		8,3	8,28	9,496	1,213	0,079	0,132	750	0,067	2,015	0,403	4,03	0,2	0,271	0,354
		16	16	18,35	2,345	0,152	0,255	750	0,13	3,894	0,779	7,788	0,2	0,237	0,28
		24	24,24	27,796	3,552	0,231	0,386	1000	0,197	5,898	1,18	11,797	0,2	0,224	0,253
		37	37,14	42,586	5,442	0,353	0,591	1000	0,301	9,037	1,807	18,074	0,2	0,216	0,234
		51	51,25	58,759	7,508	0,487	0,816	1250	0,416	12,469	2,494	24,938	0,2	0,211	0,225
		92	91,66	105,092	13,428	0,872	1,46	1250	0,743	22,301	4,46	44,602	0,2	0,206	0,214
		166	166,57	190,974	24,402	1,584	2,652	1250	1,351	40,526	8,105	81,052	0,2	0,204	0,208
		353	346,57	397,338	50,771	3,296	5,519	1250	2,811	84,318	16,864	168,635	0,2	0,202	0,204
		761	746,98	856,411	109,43	7,103	11,895	1250	6,058	181,736	36,347	363,472	0,2	0,201	0,202
		1335	1310,32	1502,28	191,958	12,461	20,865	1500	10,626	318,794	63,759	637,588	0,2	0,2	0,201
		1612	1581,84	1813,576	231,735	15,043	25,189	1500	12,828	384,853	76,971	769,706	0,2	0,2	0,201
		3414	3349,78	3840,514	490,732	31,855	53,34	1500	27,166	814,982	162,996	-	0,2	0,2	0,2
		5049	4954,15	5679,917	725,767	47,112	78,888	1500	40,177	1205,316	241,063	-	0,2	0,2	0,2
		7229	7093,66	8132,854	1039,198	67,458	112,956	1500	57,528	-	345,169	-	0,2	0,2	0,2
		15309	15021,86	17222,514	2200,654	142,851	239,202	1500	121,824	-	730,946	-	0,2	0,2	0,2

Stromag Geared Cam Limit Switches

Limit Switch Control Current

Series 100 – Steel Sheet Housing B3

Revision number: 3.1.3.3-01

Revision date: 19.11.2019

Features

- IP65 sheet steel housing foot mounted version B3
- Different kinds of housing sizes possible depending on gear and number of contacts

Application

- Crane on- and offshore

Additional information

- For rough environments
- Increased protection against corrosion through 2 component paint

Steel sheet housing B3

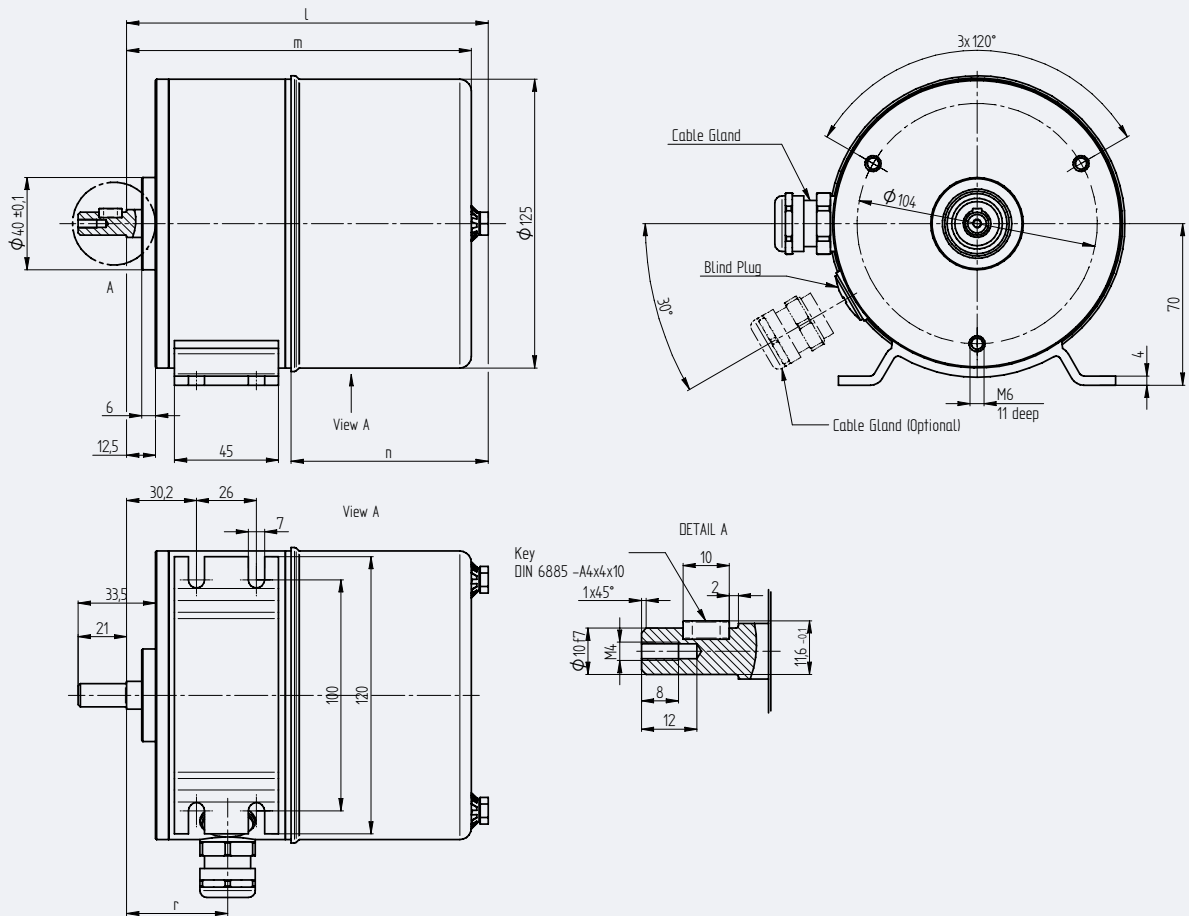

Size	1	1a	1b	1c	2	2a	2b	2c	3	3a	3b	3c	4	4a	4b	4c	5	5a	5b	5c
l	157	213	279	305	171	227	293	319	185	241	307	333	199	255	321	347	213	269	335	361
m	150	206	272	298	164	220	286	312	178	234	300	326	192	248	314	340	206	262	328	354
n	85	141	208	233	85	141	208	233	85	141	208	233	85	141	208	233	85	141	208	233
o	141,5	197,5	263,5	289,5	155,5	211,5	277,5	303,5	169,5	225,5	291,5	317,5	183,5	239,5	305,5	331,5	197,5	253,5	319,5	345,5
p	148,5	204,5	270,5	296,5	162,5	218,5	284,5	310,5	176,5	232,5	298,5	324,5	190,5	246,5	312,5	338,5	204,5	260,5	326,5	352,5
r	44	44	44	44	58	58	58	58	72	72	72	72	86	86	86	86	100	100	100	100
kg	2	2,7	4	4,7	2,2	2,9	4,2	4,9	2,4	3,1	4,4	5,1	2,6	3,3	4,6	5,3	2,8	3,5	4,8	5,5

Stromag Geared Cam Limit Switches

Limit Switch Control Current

Series 100 – Steel Sheet Housing B3 / B5

Revision number: 3.1.3.3-01

Revision date: 19.11.2019

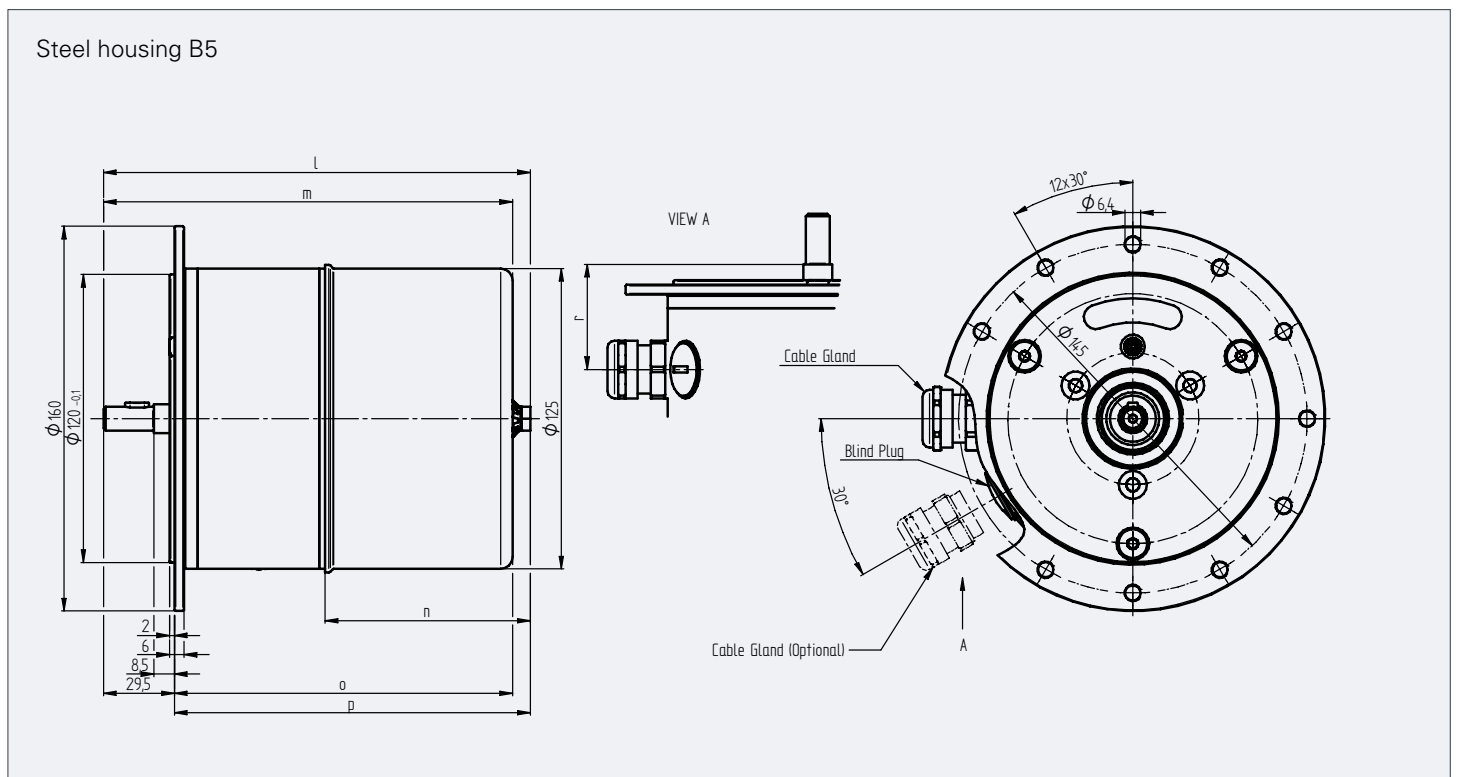
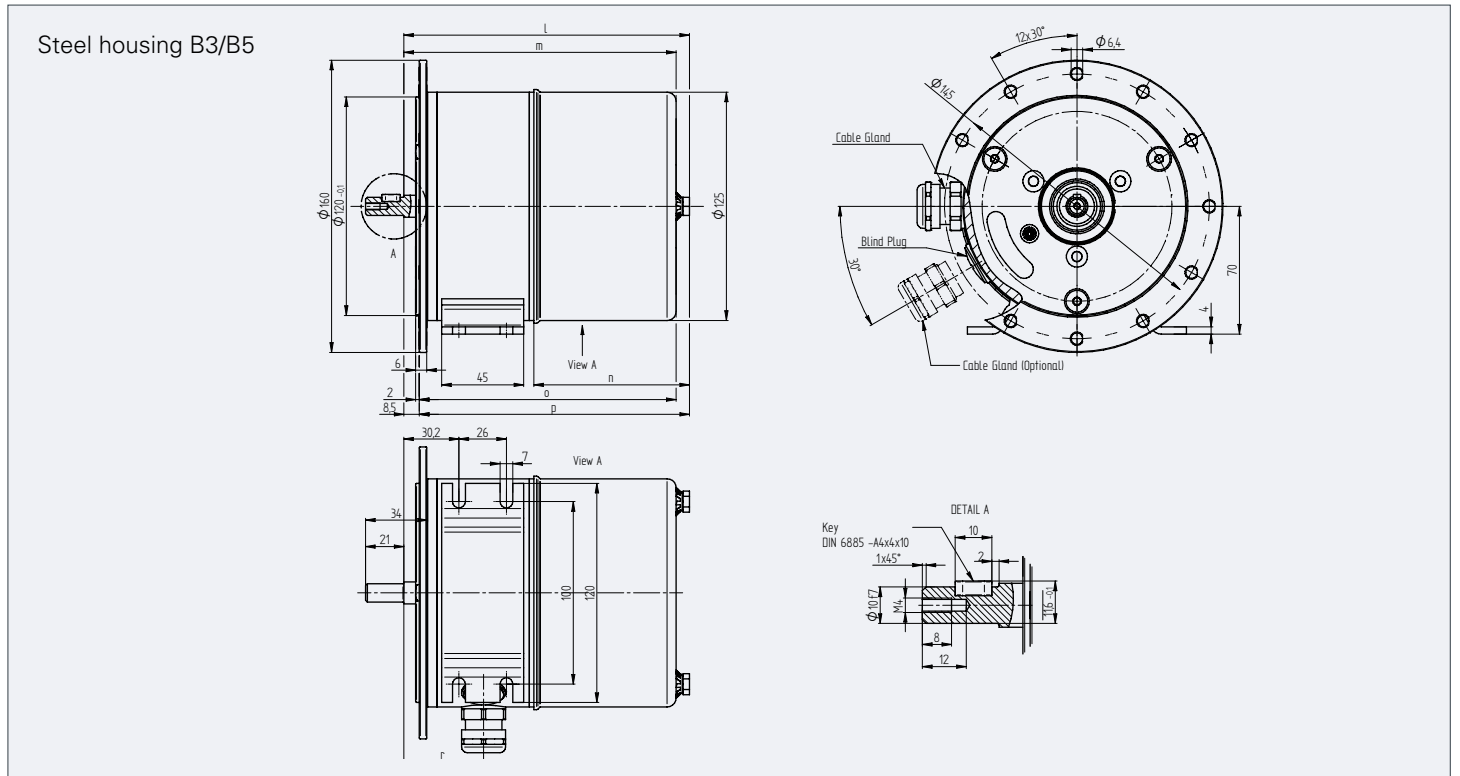

Stromag Geared Cam Limit Switches

Limit Switch Control Current

Series 100 – Steel Sheet Housing B14

Revision number: 3.1.3.3-01

Revision date: 19.11.2019

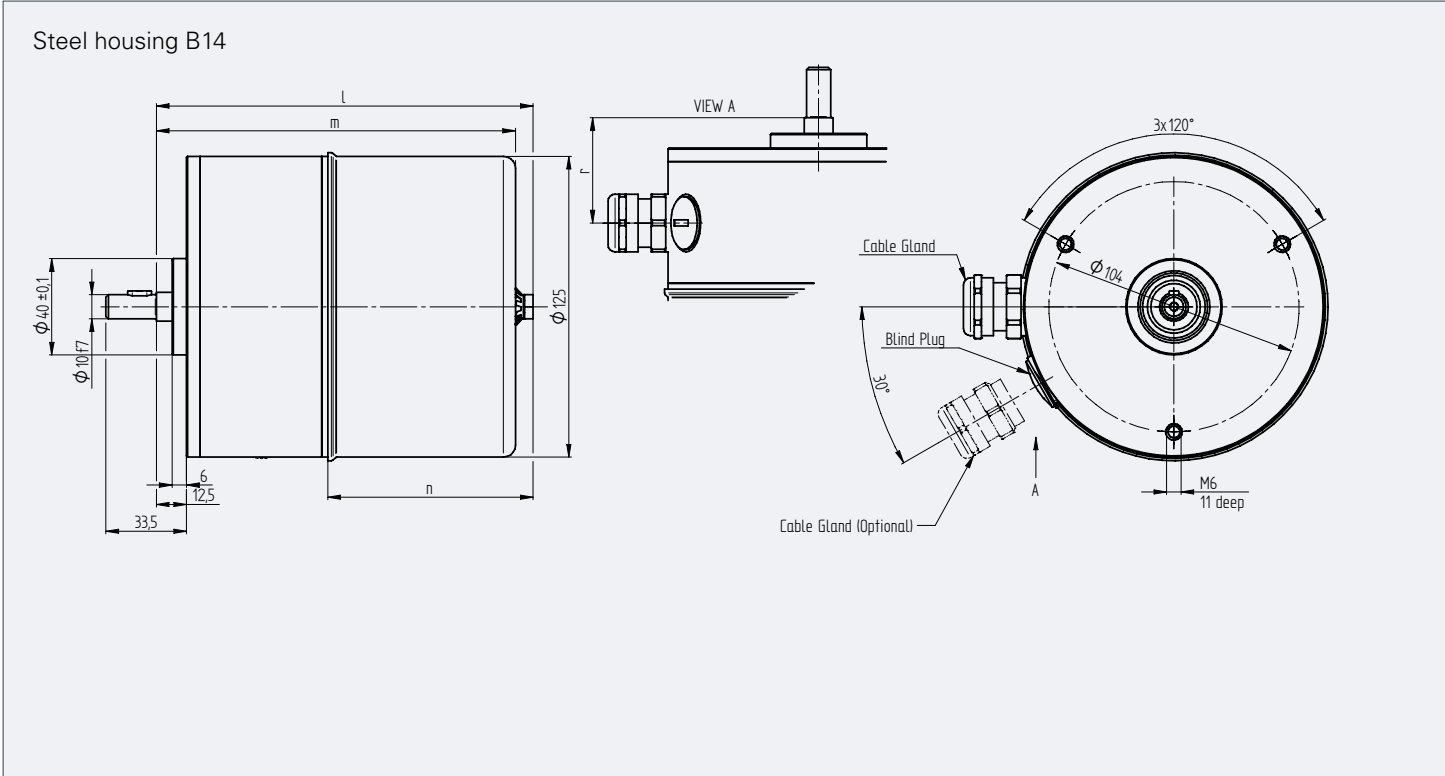

Stromag Geared Cam Limit Switches

Limit Switch Control Current

Series 100 – Cast Iron Housing B3

Revision number: 3.1.3.4-01

Revision date: 19.11.2019

Features

- IP66 cast iron housing foot mounted version B3
- Different kinds of housing sizes possible depending on gear and number of contacts

Application

- Crane on- and offshore
- Nuclear
- Steel works

Additional information

- For extreme rough environments
- Increased protection against corrosion through 2 component paint

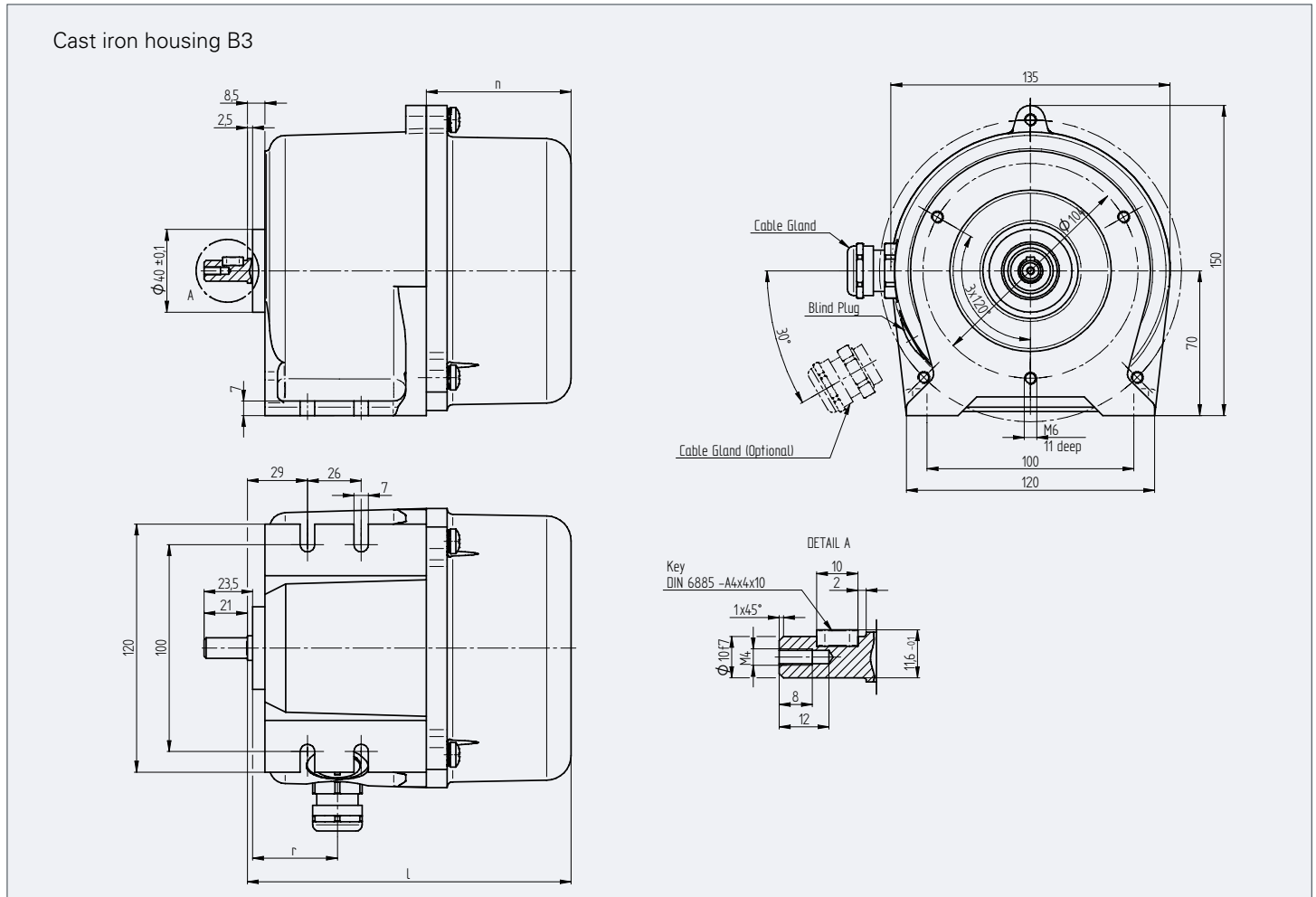

Size	1	1a	1b	1c	2	2a	2b	2c	3	3a	3b	3c
l	156,5	216,5	278	303	170,5	230,5	292	317	184,5	244,5	306	331
m	152	214,5	273,5	298,5	166	226	287,5	312,5	180	240	201,5	326,5
n	70	130	191,5	216,5	70	130	191,5	216,5	70	130	191,5	216,5
r	41	41	41	41	55	55	55	55	69	69	69	69
kg	5	5,3	5,6	5,8	5,45	5,75	6,05	6,25	5,9	6,2	6,5	6,7

Stromag Geared Cam Limit Switches

Limit Switch Control Current

Series 100 – Cast Iron Housing B3 / B5

Revision number: 3.1.3.4-01

Revision date: 19.11.2019

Cast iron housing B3/B5

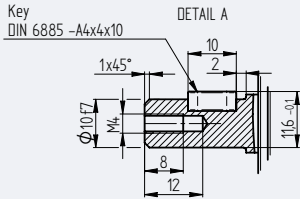
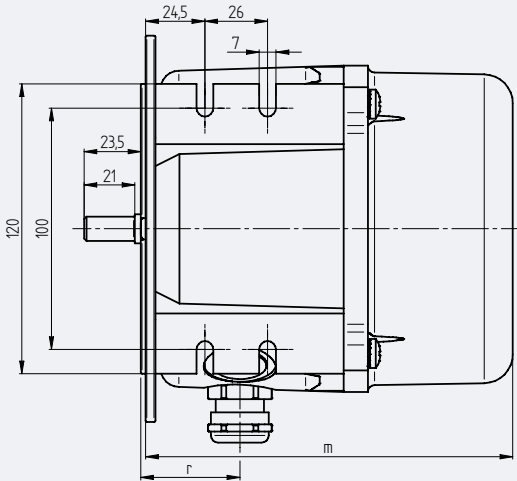
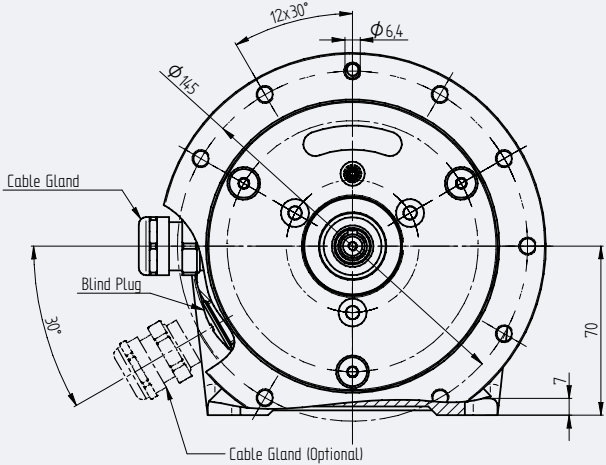
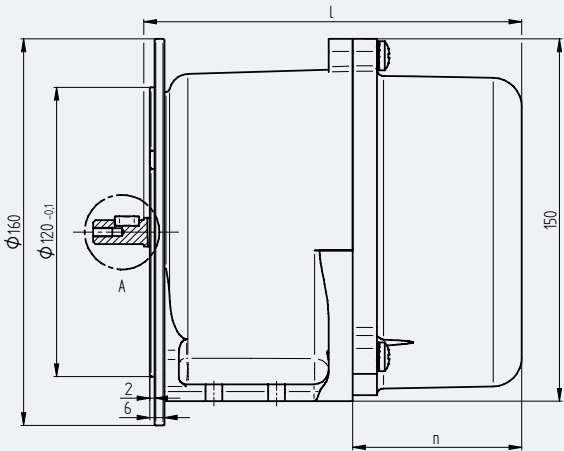

Stromag Geared Cam Limit Switches

Limit Switch Control Current

Series 110 – Polycarbonate Housing B3

Revision number: 3.1.3.5-01

Revision date: 19.11.2019

Features

- IP66 reinforced polycarbonate housing, foot mounted version B3
- Different kinds of sizes possible depending on number of contacts

Application

- Crane on- and offshore
- Treatment plants

Additional information

- For rough environments
- High resistance against corrosion

Polycarbonate housing B3

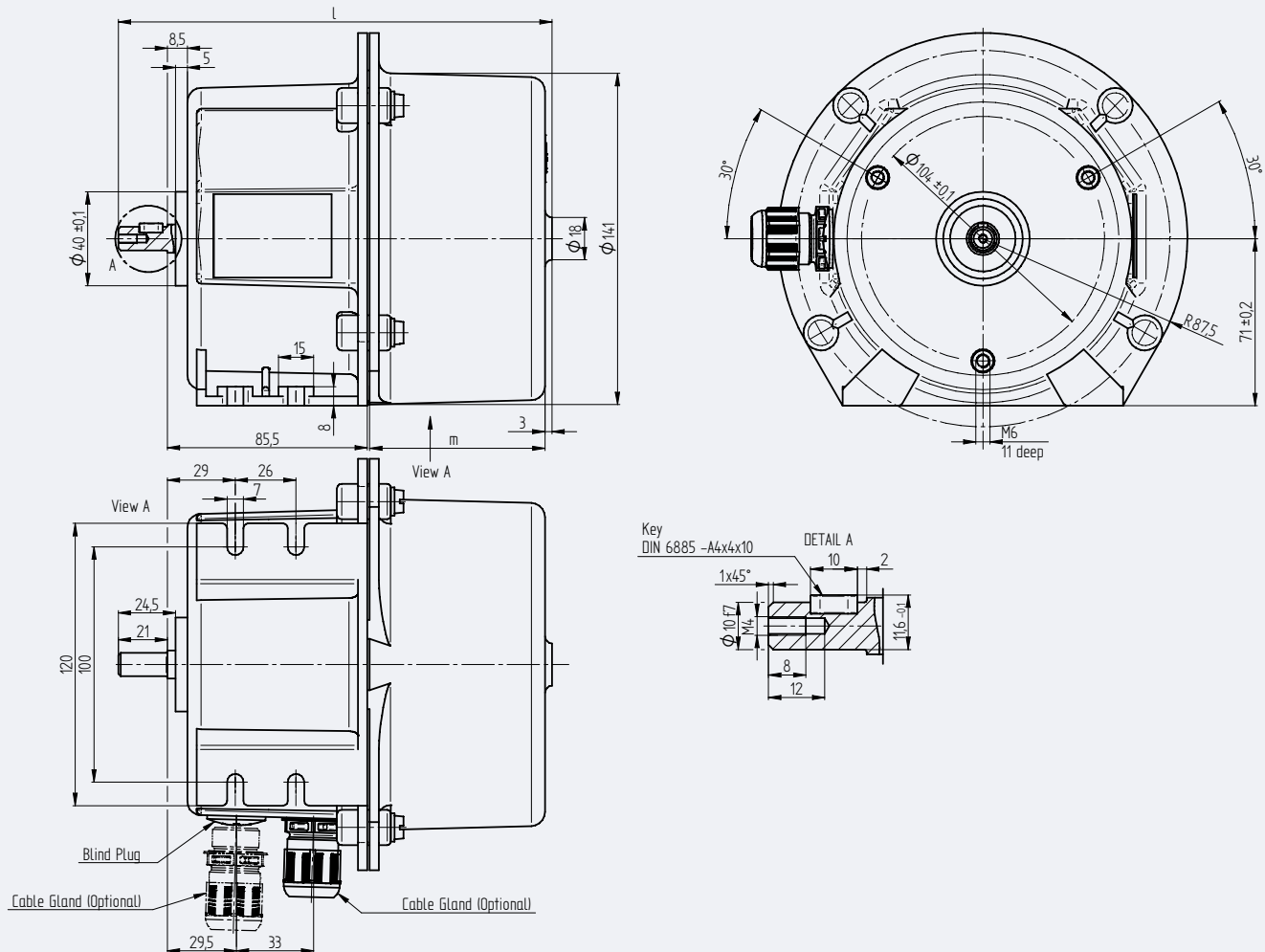

Size	a	b	c
l	185,5	250,5	310,5
m	75	140	200
n	160	225	285
kg	1,6	2	2,4

Stromag Geared Cam Limit Switches

Limit Switch Control Current

Series 110 – Polycarbonate Housing B3 / B5

Revision number: 3.1.3.5-01

Revision date: 19.11.2019

Polycarbonate housing B3 / B5

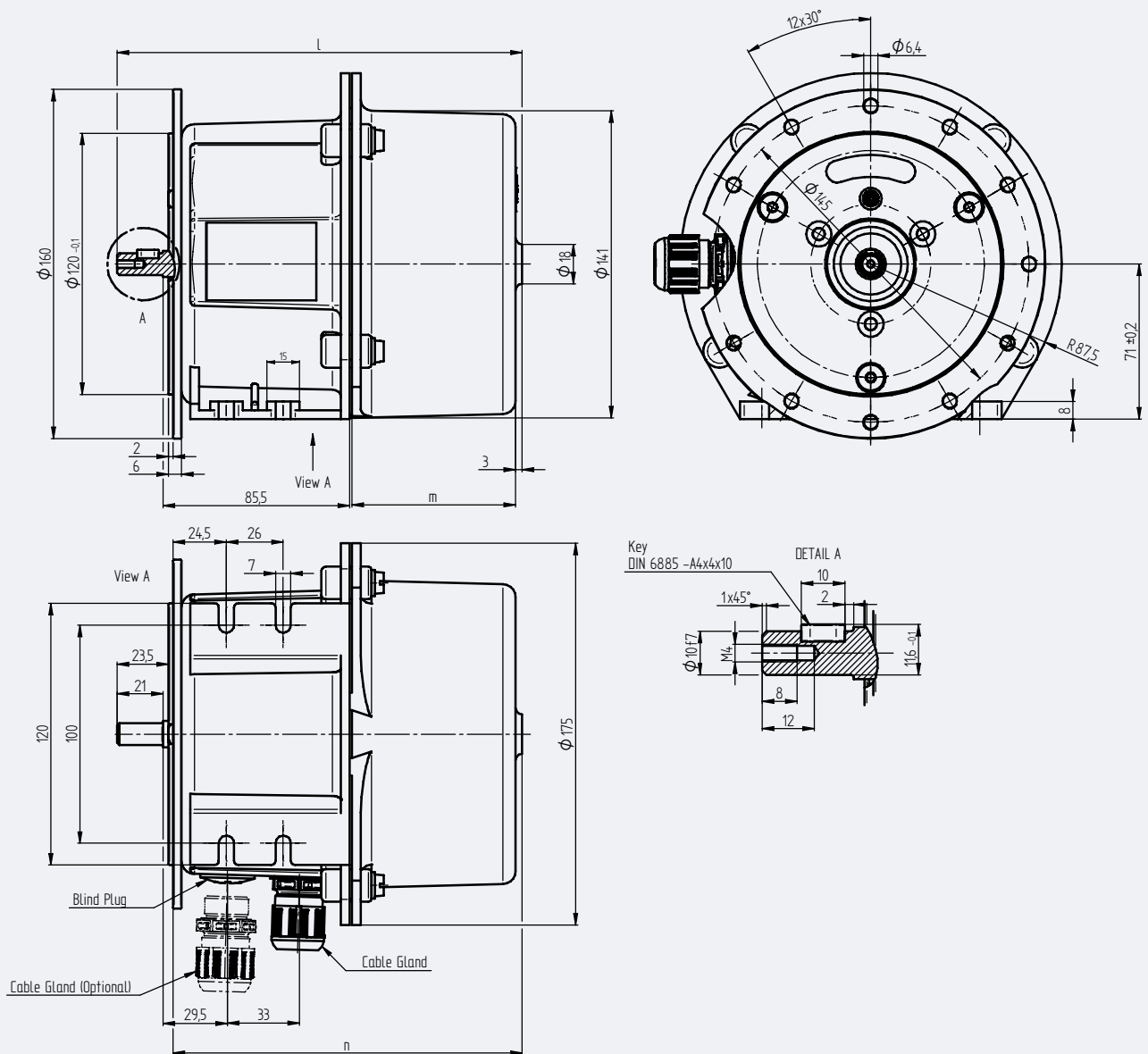

Stromag Geared Cam Limit Switches

Limit Switch Control Current

Series 100 – Lever Limit Switch

Revision number: 3.1.3.6-01

Revision date: 19.11.2019

Features

- Different type and number of contacts possible

Application

- Cranes

Additional information

- Actuation to both sides standard

Series 100 lever switch
in neutral position

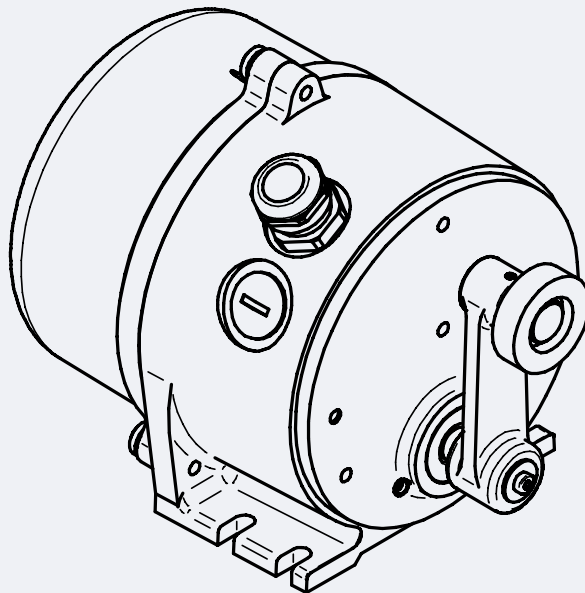

Series 100 lever switch
in switched position

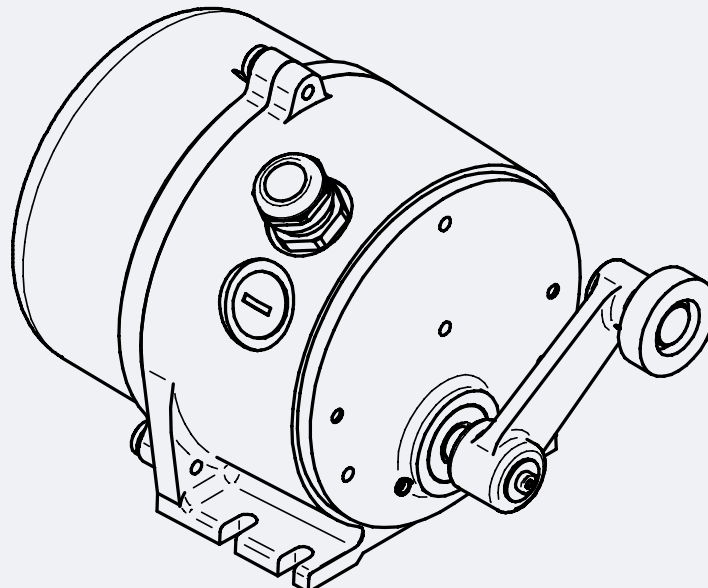

Stromag Geared Cam Limit Switches

Limit Switch Control Current

Series 100 – Available Levers

Revision number: 3.1.3.7-01

Revision date: 19.11.2019

Features

- Execution with lever with roller or wide roller available

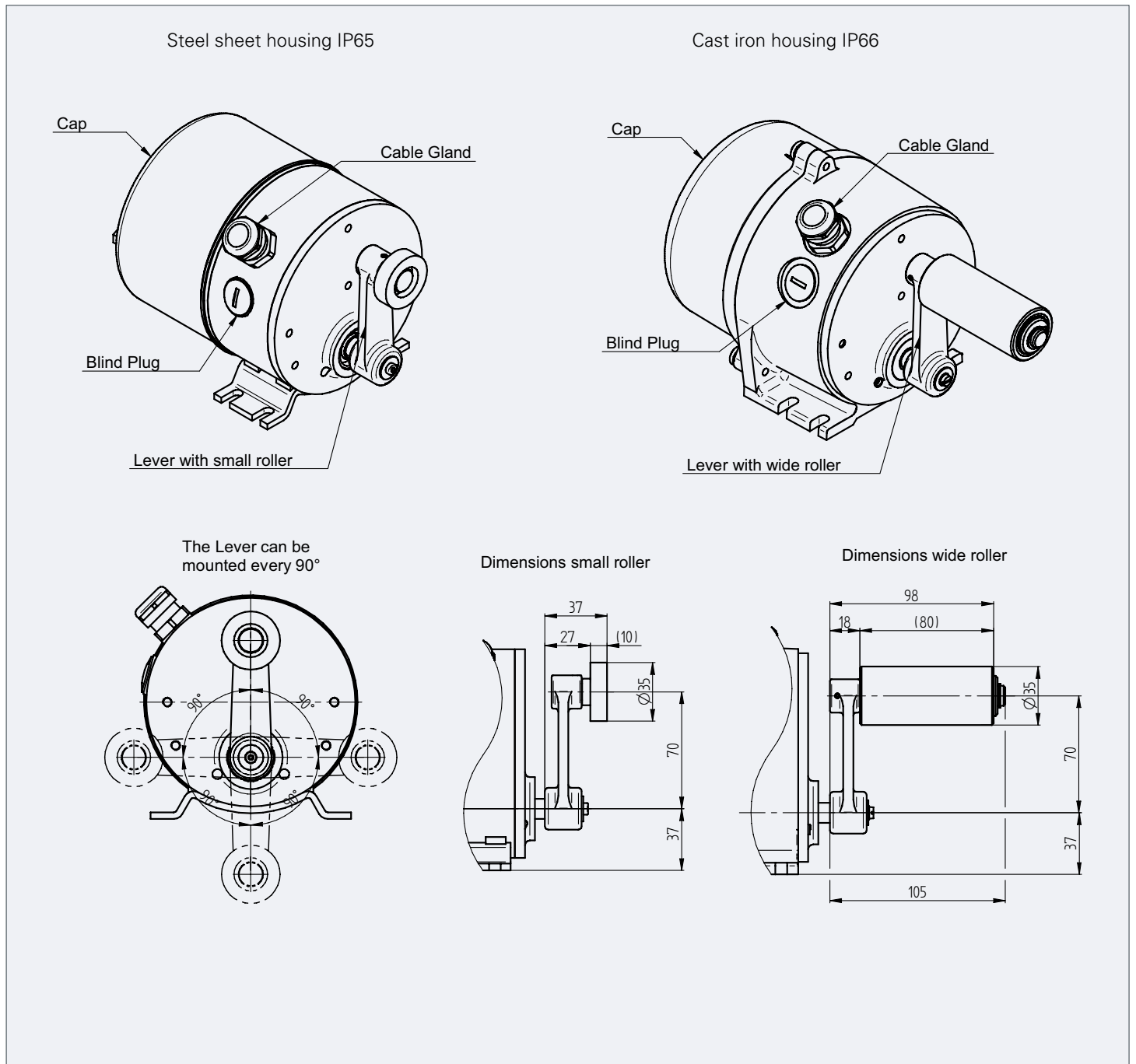

Stromag Geared Cam Limit Switches

Limit Switch Control Current

Series 100 – Lever Limit Switch Steel Sheet Housing

Revision number: 3.1.3.8-01

Revision date: 19.11.2019

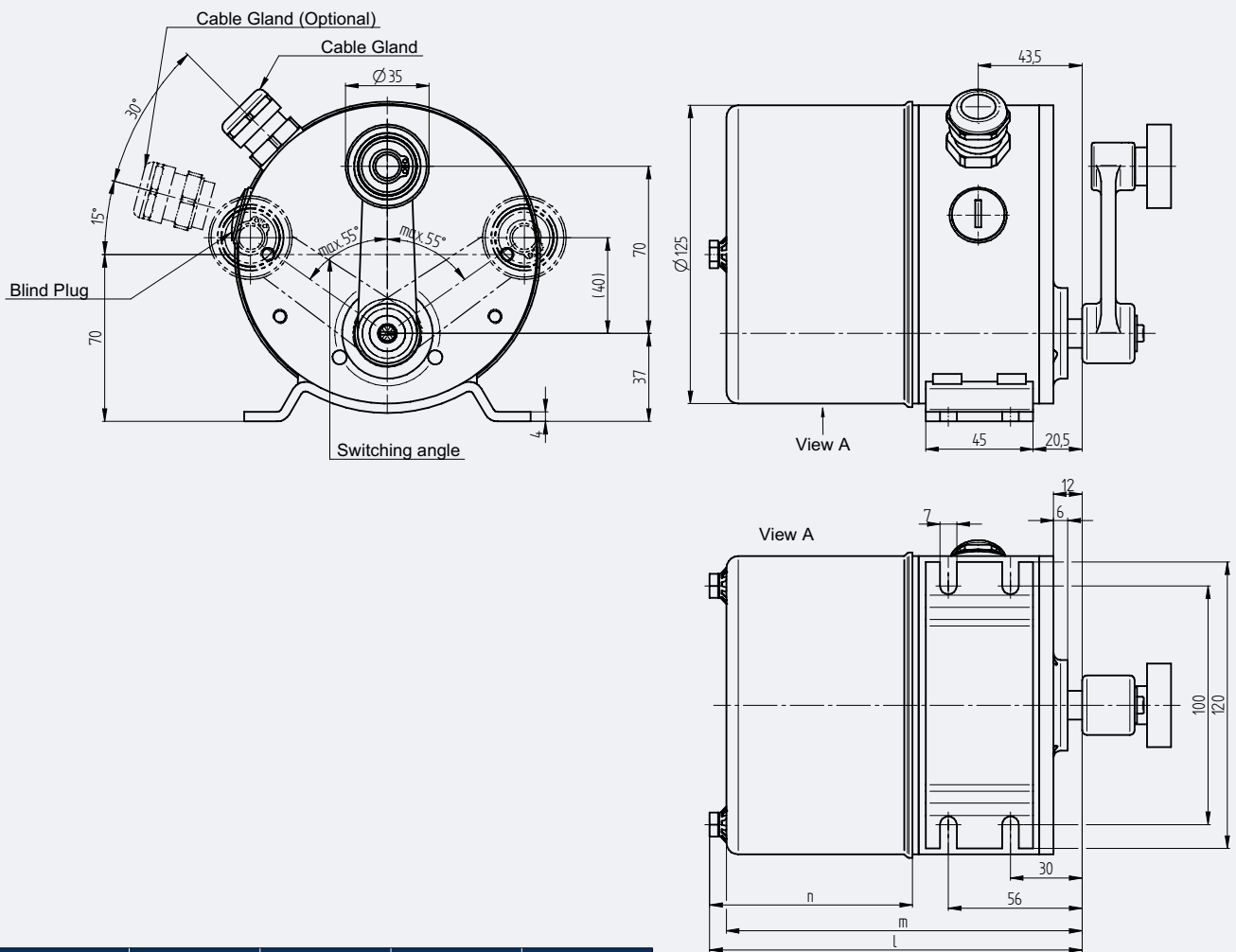

Size	1	1a	1b	1c
l	156	212	278	304
m	149	205	271	297
n	85	141	208	233
Max. number of contacts	4	8	12	14

Stromag Geared Cam Limit Switches

Limit Switch Control Current

Series 100 – Lever Limit Switch Cast Iron Housing

Revision number: 3.1.3.9-01

Revision date: 19.11.2019

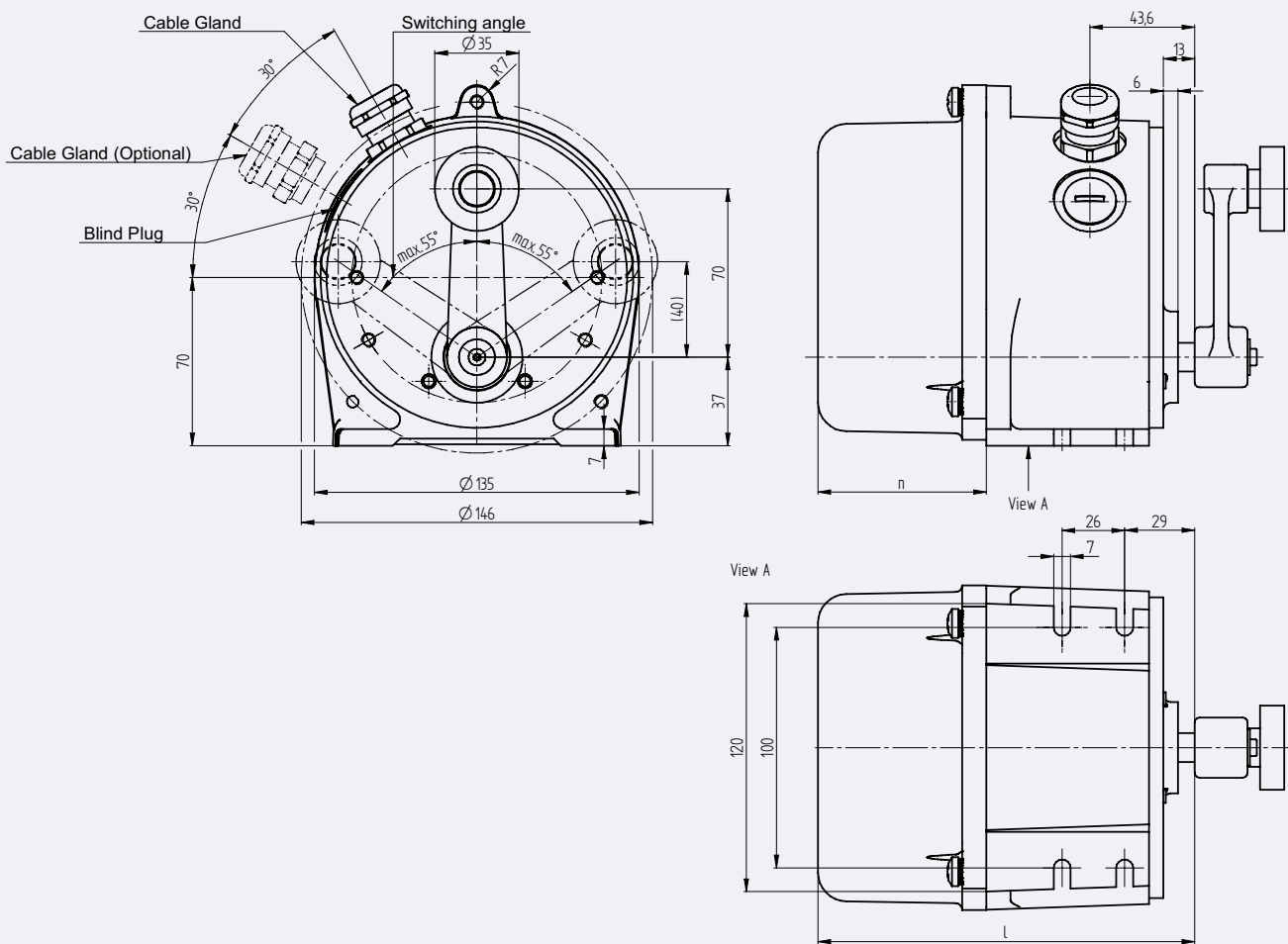

Size	1	1a	1b	1c
l	156,5	216,5	278	303
n	70	130	191,5	216,5
Max. number of contacts	4	8	12	14

Stromag Geared Cam Limit Switches

Limit Switch Control Current

Series 100 – Counterweight Limit Switch

Revision number: 3.1.3.10-01

Revision date: 19.11.2019

Features

- Safety limit switch redundant additional to the geared cam limit switch for the emergency stop of the hook travel

Application

- Cranes onshore

Additional information

- Rope in different length available
- Rope reeving for different kind of rope diameter available

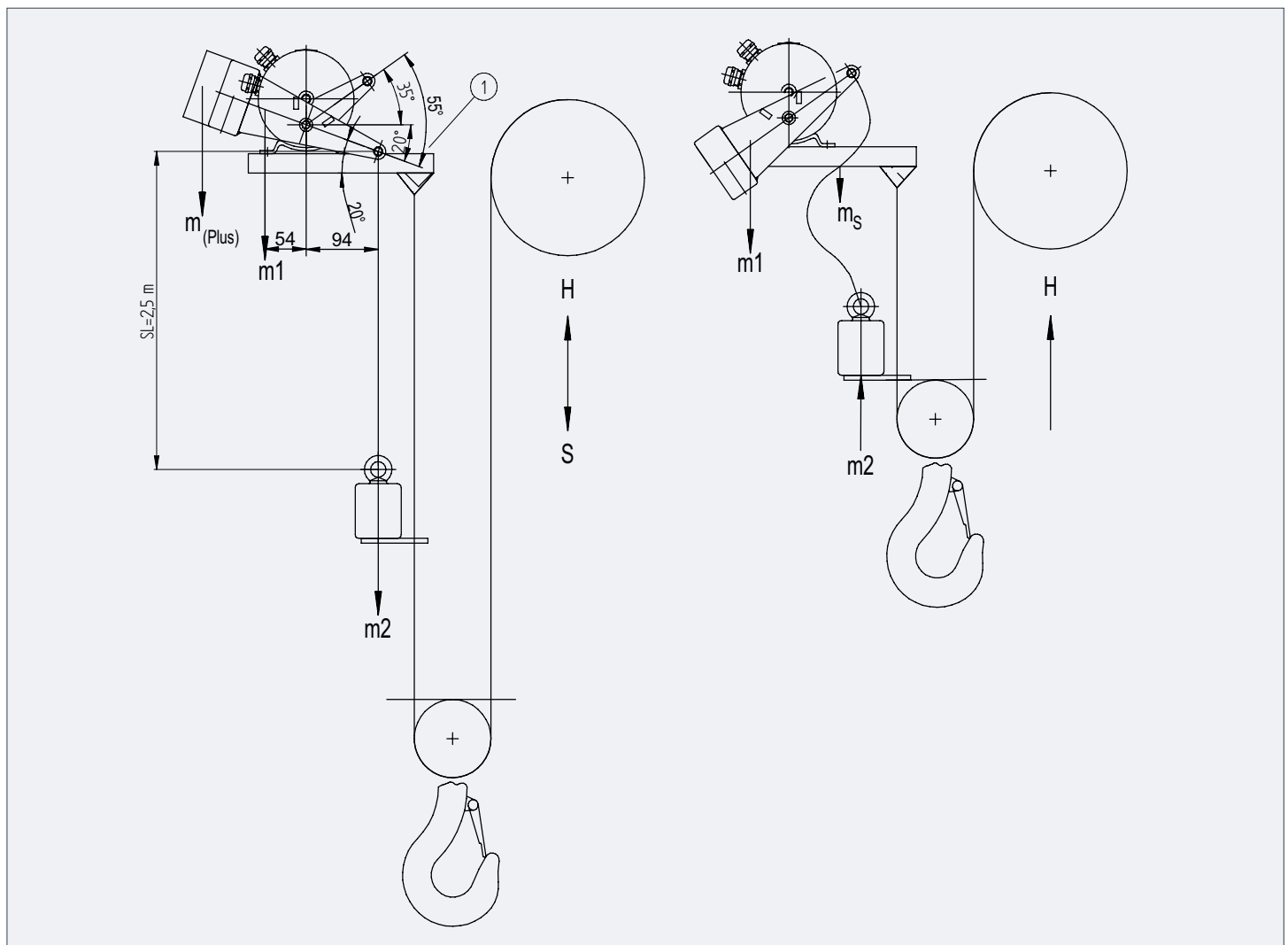

A Normal operation
Techn. condition: $m1 < m2$

B Emergency-stop shutdown
Techn. condition: $m1 > m_s$

1 Switching angle

2 Hoist rope ($d = 6 \text{ mm}$)
rope length according to the castor run of the drive

H Lift

m1 Counterweight lever

m2 Counterweight

m_s Rope weight

m_(plus) Additional weight

S Lower

Stromag Geared Cam Limit Switches

Limit Switch Control Current

Series 100 – Counterweight Limit Switch Iron Cast Housing

Revision number: 3.1.3.12-01

Revision date: 19.11.2019

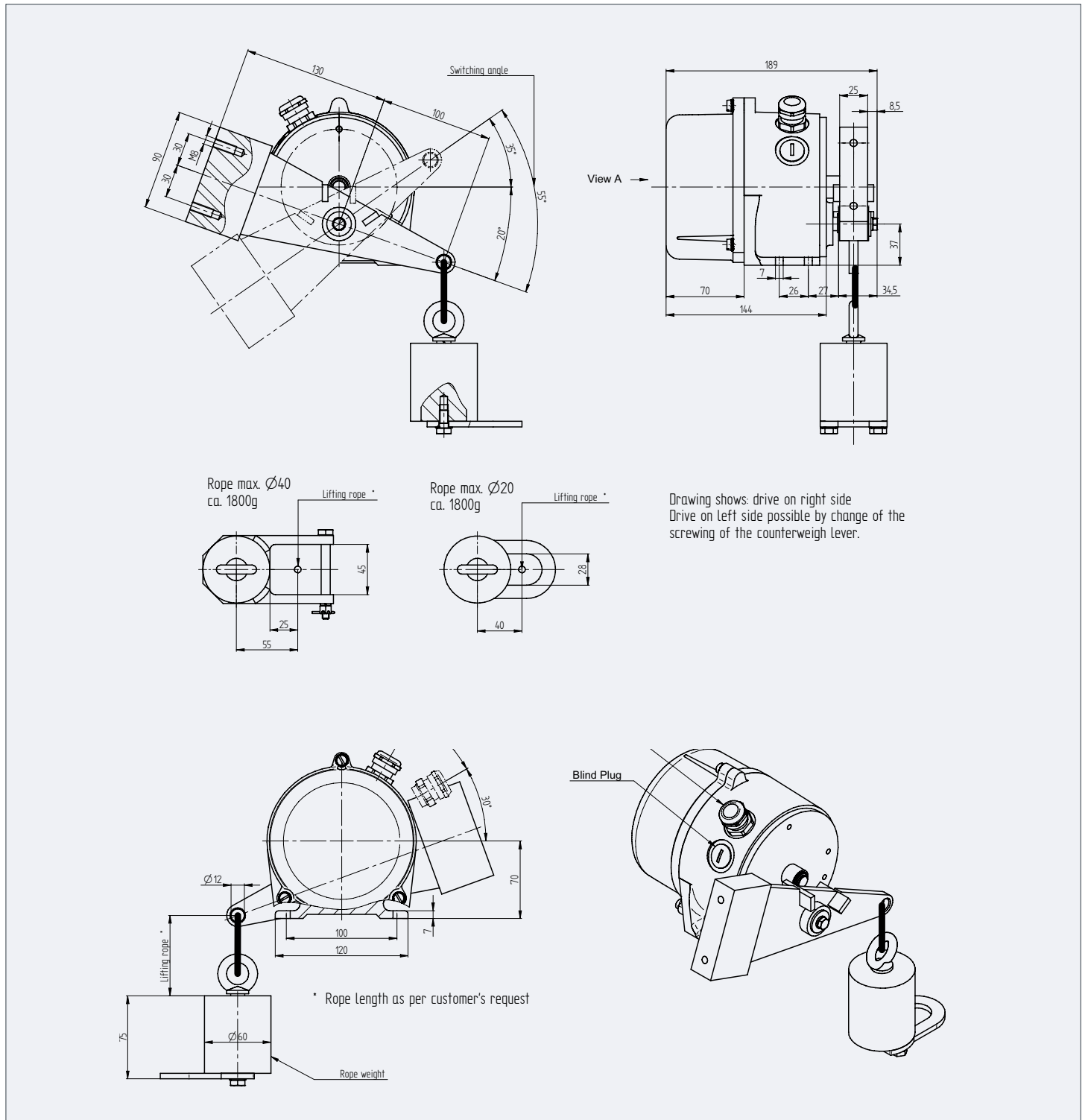

Stromag Geared Cam Limit Switches

Limit Switch Control Current

Series 100 / 110 – Available Switches

Revision number: 3.1.3.13-03

Revision date: 31.03.2022

Features

- Snap – and push action contacts available in silver and gold
- Isolated contact elements possible
- Positive opening contacts available

Application

- For relays or PLC

Additional information

- Contact 52 and 53 usable for radioactive environment
- Contact 51 and 54 for temperature up to +120° Celsius

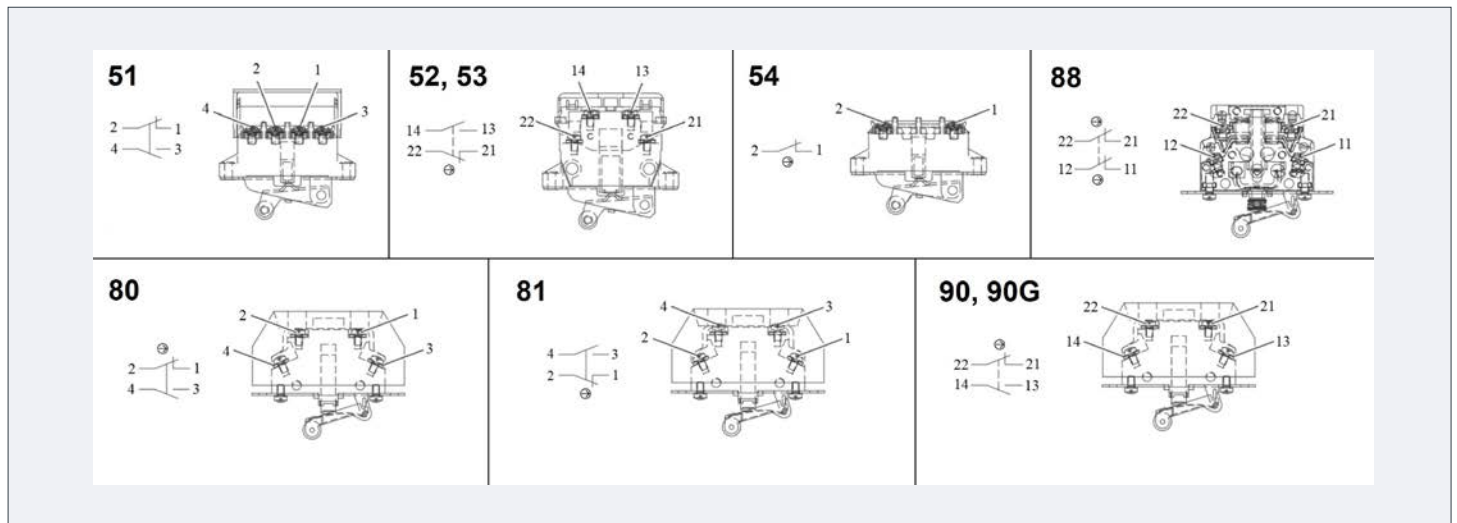

Switching contact		Contact material		Switching system		Connection	Electrical data					Additional data			
Designation	Circuit as a changeover	Circuit as an NC contact	Silver	Gold (PLC-Application)	Snap action switch		Push action switch	Screw terminals: 0,75 - 2,5 mm ² AWG 14 ... 20	Utilization category acc. to IEC 60947	Conventional thermal current I _{th}	Rated Insulation Voltage U _i	Short circuit protection	Degree of Pollution	Mechanical Lifetime	Positive opening acc. to EN 60947-5-1 Annex K
51	•			•	•	•	AC-15: 230V, 2,5A DC-13: 24V, 4A		6A	250V	10A gL/gG	PD 2	30x106		-30°C ... +85°C *
52	•			•	•	•	AC-15: 230V, 2,5A DC-13: 24V, 6A		10A	250V	6A gL/gG	PD 3	1x106	•	-30°C ... +85°C
53	•			•	•	•	AC-15: 230V, 2,5A DC-13: 24V, 6A		10A	250V	6A gL/gG	PD 3	1x106	•	-30°C ... +85°C
54		•	•		•	•	AC-15: 230V, 2,5A DC-13: 24V, 1A		6A	250V	10A gL/gG	PD 2	30x106	•	-30°C ... +85°C *
80	•		•		•	•	AC-15: 230V, 3A DC-13: 110V, 1A		10A	400V	6A gG	PD 3	10x106	•	-40°C ... +85°C
81	•		•		•	•	AC-15: 230V, 3A DC-13: 110V, 1A		10A	400V	6A gG	PD 3	10x106	•	-40°C ... +85°C
90	•		•		•	•	AC-15: 230V, 1A DC-13: 110V, 0,5A		10A	400V	6A gR	PD 3	10x106	•	-40°C ... +85°C
90G	•		•		•	•	AC-12: 230V, 0,25A, DC-12: 110V, 0,25A		10A	400V	2A gG	PD 3	10x106	•	-40°C ... +85°C
88		•	•	•		•	AC-15: 230V, 1,5A DC-13: 24V, 1,5A		10A	400V	10A gG	PD 3	1,5x106	•	-40°C ... +85°C

• = applicable

* Up to +120°C in combination with high temperature type

Stromag Geared Cam Limit Switches

Limit Switch Control Current

Series 100 / 110 – Cam Disc Types

Revision number: 3.1.3.14-01

Revision date: 19.11.2019

Features

- Easy adjustable cam discs via self-locking worm, gear ratio of 74
- Large cam disc diameter for high switching point accuracy

Additional information

- FV for normal application
- DFV for flexible adjustment of the cam angle
- DV for radioactive and high temperature application

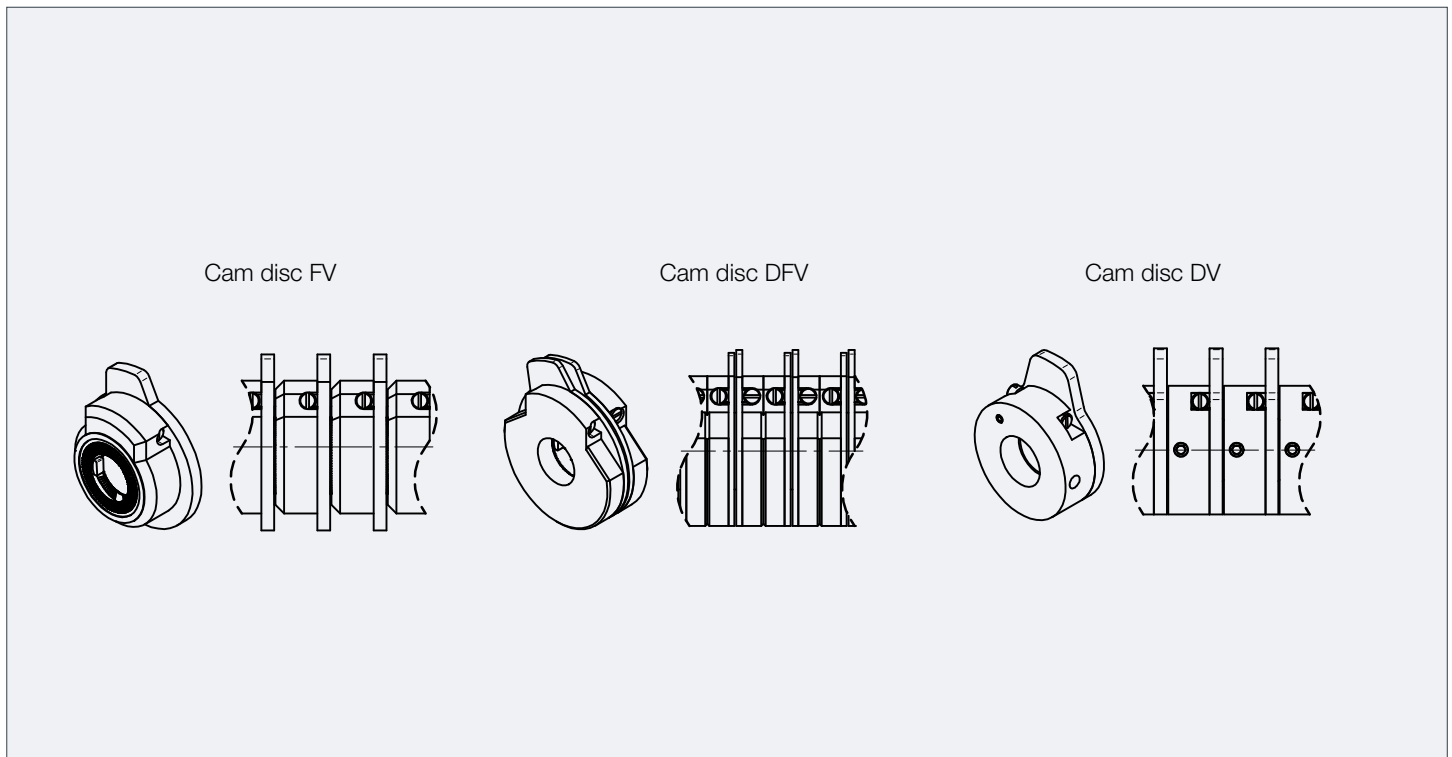

Cam DiscTypes	Standard Cam Angle	Special Cam Angel	Gradation Cam Angle	Disc Material
FV	40°	Other cam angles on request.	1°	Synthetic Material
DFV	40°		1°	Synthetic Material
DV	40°		1°	Brass

Stromag Geared Cam Limit Switches

Limit Switch Control Current

Series 100 / 110 – Option Anti-Condensation-Heating

Revision number: 3.1.3.15-02

Revision date: 06.09.2022

Features

- Self-regulating PTC heating element

Application

- For anti-condensation to avoid water condensation within the geared cam limit switch

Additional information

- Additional safety for usage in low temperatures

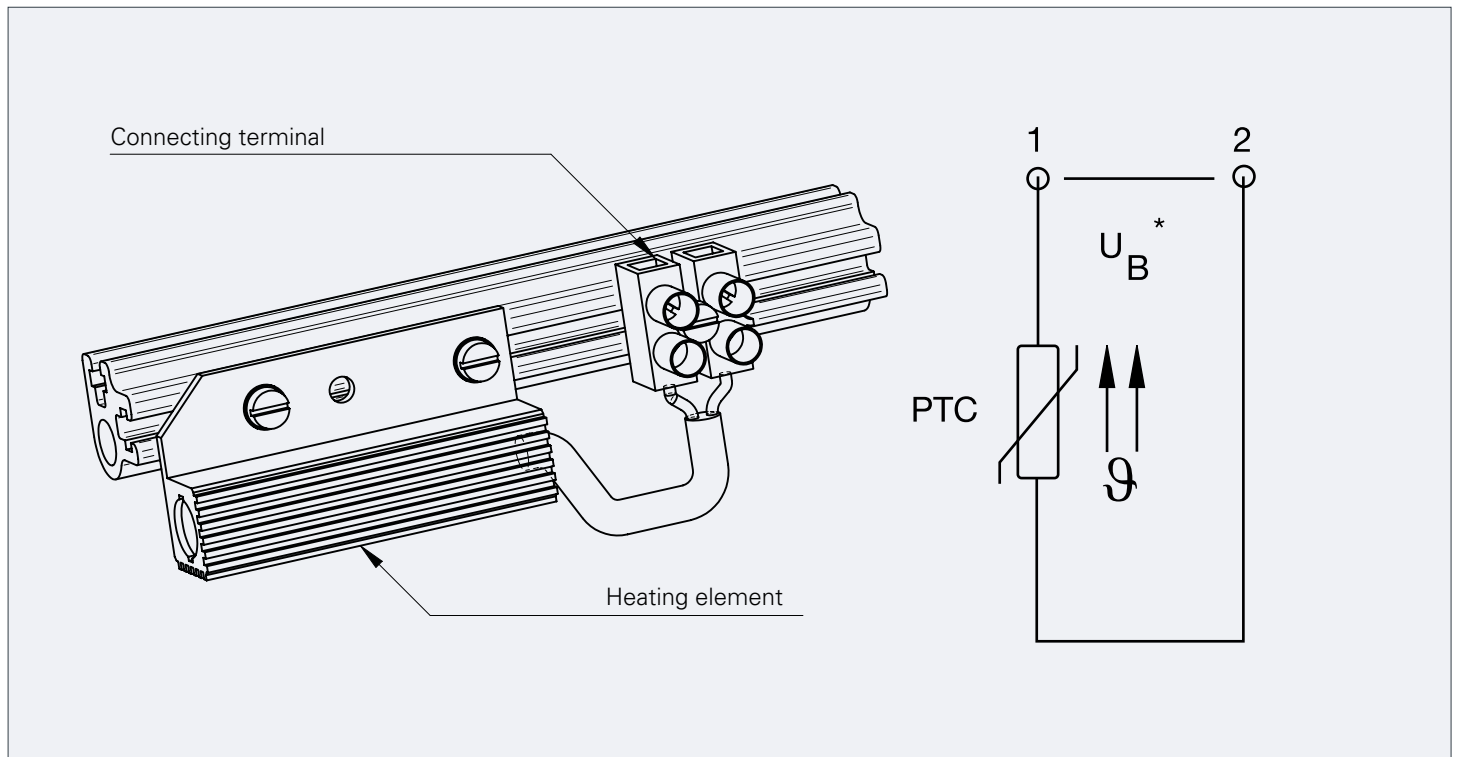

Design	H1	H2
Supply Voltage U_{BB}	12 – 30 V AC/DC	110 – 250 V AC/DC
Heat Output	ca. 2.5 Watts	ca. 4 Watts
PTC Cooling resistor (at 25 °C) R_{25}	20 $\Omega \pm 35 \%$	1500 $\Omega \pm 35 \%$
PTC Reference temperature	50 °C	50 °C
Protection class (VDE 0100, 0160)	II	II
Connecting cable	2 x 0,25 mm ² , Silicon cable	2 x 0,25 mm ² , Silicon cable
Radiator	Anodised aluminum	Anodised aluminum
Weight	approx. 40 g	approx. 40 g

Stromag Geared Cam Limit Switches

Limit Switch Control Current

Series 100 / 110 – Option Drive Flange F, F+M

Revision number: 3.1.3.16-01

Revision date: 19.11.2019

Features

- For easy connection to the machine

Application

- Cranes

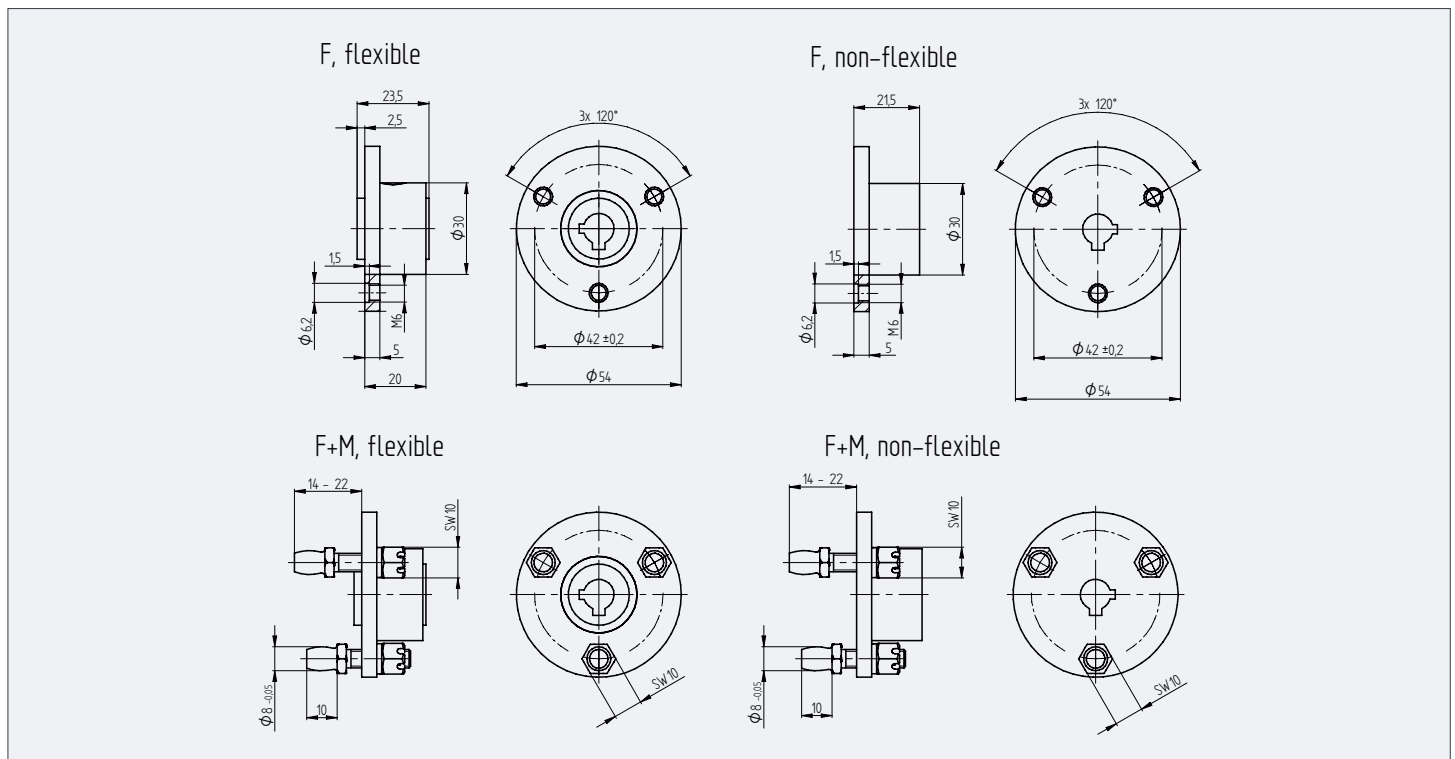

Flange	Type	Operating speed	Torsion angle (with a torque of 5 Nm)	Comment
F	flexible	$n_{max} = 1000$ rpm	$5 \pm 0.5^\circ$	not for Counterweight and Lever Switches
F	non-flexible	$n_{max} = 1000$ rpm	0°	not for Counterweight and Lever Switches
F+M	flexible	$n_{max} = 1000$ rpm	$5 \pm 0.5^\circ$	not for Counterweight and Lever Switches
F+M	non-flexible	$n_{max} = 1000$ rpm	0°	not for Counterweight and Lever Switches

Series 100 / 110 – Customizable Cam Discs

Revision number: 3.1.3.17-01

Revision date: 19.11.2019

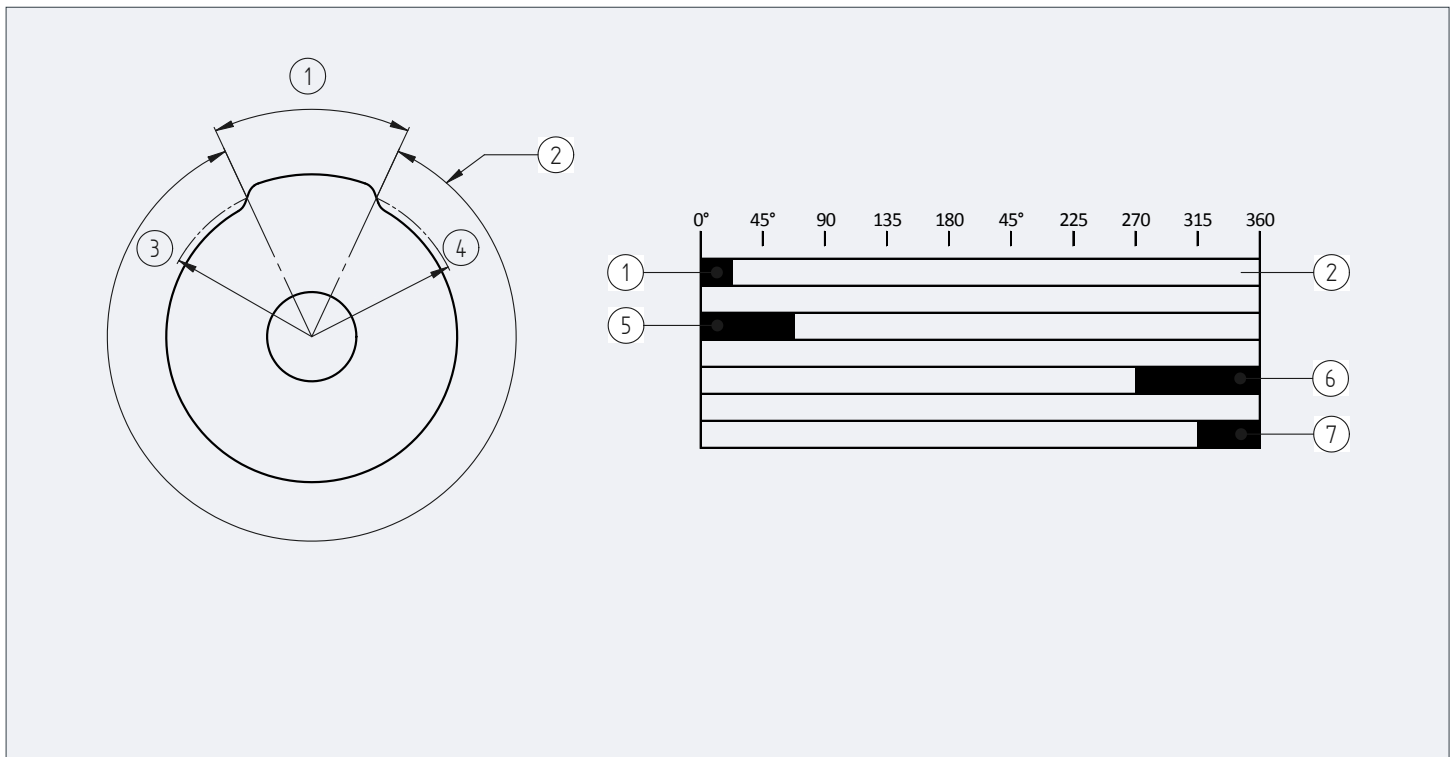

- A Cam angle diagram
 1 Effective cam angle α (=castor angle)
 2 Effective cam angle β
 3 Switching point radius
 4 Reset point radius

- B Application examples
 1 Effective cam angle 15°
 5 Effective cam angle 60°
 6 Effective cam angle 90°
 7 Effective cam angle 45°

The cam discs are named due to the effective cam angle. The effective cam angle corresponds to the switching point angle on the switching point radius of the cam disc. Standard cam angle for series 100/110 is 40°.

Any other cam angles (from 15° up to 345°) can be supplied as a special design upon request. The usable revolutions enabled by a cam disc on the drive shaft, result in the following:

$$U = \frac{\beta \cdot i}{360^\circ} = \frac{(360^\circ - \alpha) \cdot i}{360^\circ} = 1 - \frac{\alpha \cdot i}{360^\circ}$$

- U = Usable revolutions
 α = Effective cam angle
 β = Usable cam angle ($\beta = 360^\circ - \alpha$)
 i = gear ratio

Stromag Geared Cam Limit Switches

Limit Switch Control Current

Series 100 – High Temperature & Radioactive Environment

Revision number: 3.1.3.18-01

Revision date: 19.11.2019

Features

- Usable for temperatures up to + 120°C with contact 51 and 54
- Contact 52 and 53 for radioactive application

Additional information

- Only cast iron housing for radioactive environment
- Radiation in gray has to be told to evaluate the usability

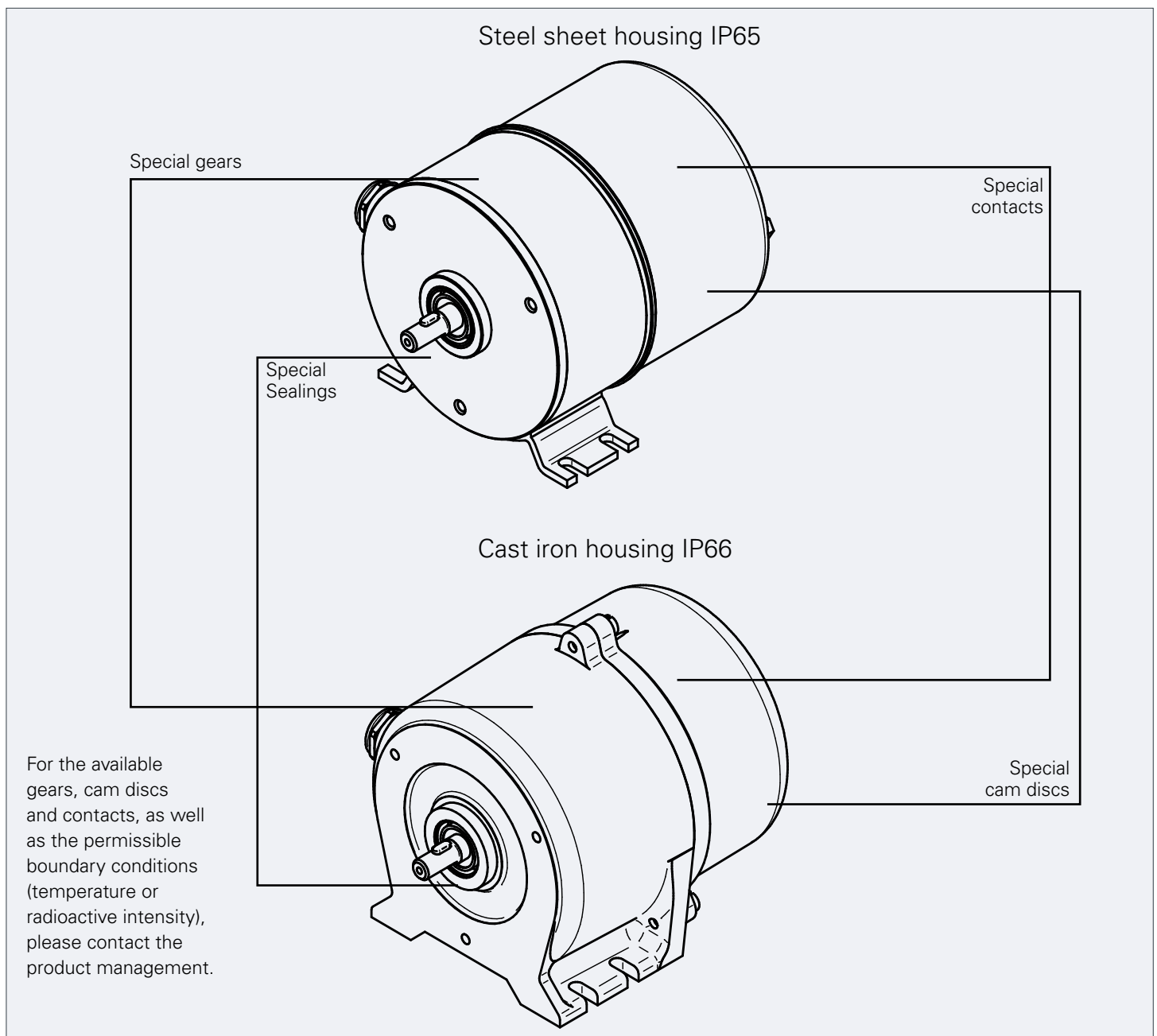



Stromag Geared Cam Limit Switches

Limit Switch Control Current

Series 100 / 110 – Key of Types

Revision number: 3.1.3.19-01

Revision date: 19.11.2019

Stromag GmbH		Hansastr. 120.D 59425 Unna Tel. +49 (0)2303 102-0	
Made in Germany Getriebeendschalter		德国制造 凸轮开关	
			
TYP 型号			
Auftr.-Nr.		Nr.	
Ref-Nr:			
U _i	V~	I _{the}	A
IP	Bauj.		
			

Switch type: GCLS Series 100/110			
100	Type of housing	100	Series 100 Limit Switch (metal housing)
		110	Series 110 Limit Switch (synthetic housing)
166	Usable revolutions	Suitable for GNE, HNE	0
		Suitable for 100/110	0.153, 0.45, 0.76, 0.91, 1; 1.69, 5, 6.4, 8.3, 16, 24, 37, 51, 92, 166, 353, 420, 761, 1335, 1612, 3414, 5049, 7229, 15309
NE	Type of limit switch	NE	Geared Cam Limit Switch
		GNE	Counterweight switch
		HNE	Lever switch
4	Number of contacts fitted	110 (NE)	1 - 12
		100 (NE)	1 - 14
		100 (GNE, HNE)	1 - 4
51	Type of contacts fitted	80	Contact (changeover) with screw connections, contact material: Silver Ü
		81	Contact (push action) with screw connections, contact material: Silver Ü
		88	Contact (double action) with screw connections, contact material: Gold Ü
		90	Contact (changeover) with screw connections, contact material: Silver Ü
		90G	Contact (changeover) with screw connections, contact material: Gold Ü
		51	Snap-action with screw-terminals, contact material: gold
		52	Contact (changeover) with screw connections, contact material: Gold Ü
		53	Contact (push action) with screw connections, contact material: Gold Ü
FV	Type of cam discs fitted	FV	Precise adjustable points of actuation
		DV	Adjustable points of actuation, cam material: Brass
		DFV	Precise, double-adjustable points of actuation

Stromag Geared Cam Limit Switches

Limit Switch Control Current

Series 100 – Special Type ATEX

Revision number: 3.1.3.20-01

Revision date: 19.11.2019

ATEX marking



II 2G Ex h IIC T4 Gb

<-- Marking for gas atmosphere

II 2D Ex h IIIB T125°C Db

<-- Marking for dust atmosphere



II 3D Ex h IIIB T125°C Dc

<-- Marking for dust atmosphere

Explanation of markings

II	Group II, devices for use above ground
2G/2D/3D	2G: Device category (for use in Zone 1 and 2) 2D: Device category (for use in Zone 21 and 22) 3D: Device category (for use in Zone 22)
h	Type of protection h, protection constructional safety "c" (EN 80079-37)
IIC/IIIB	Gas group IIC (includes group IIB and IIA) Dust group IIIB, non-conductive dust (includes group IIIA)
T125°C	Maximum permitted surface temperature
Gb/Db/Dc	Equipment protection level (EPL) as per EN 80079-36

Technical details

Temperature range:	-20°C to 60°C -40°C to 60°C (Cold Climate Version)
Number of contacts:	1-8 Contacts
IP Protection class:	IP64: Steel Sheet Housing IP66: Cast Iron Housing
Rotation speed:	max. 1500 rpm (depending on chosen gear reduction)

Steel Sheet Housing

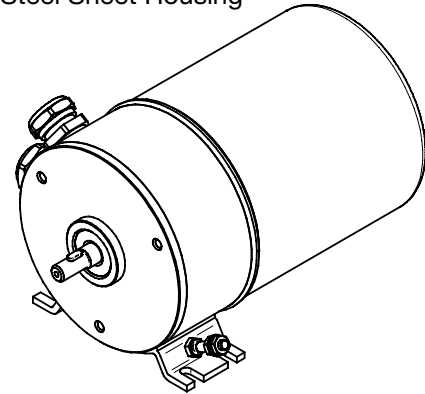

Cast Iron Housing

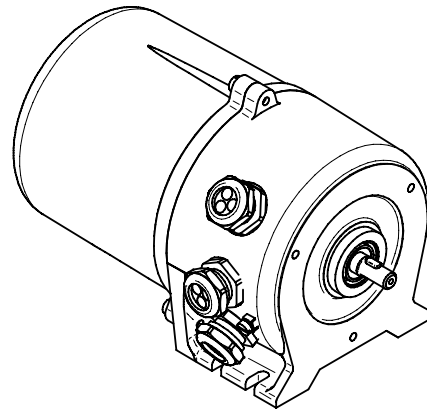

Available Switches for device categories 2G, 2D and 3D

Switching contact			Contact material		Switching system		Connection	Electrical data				Additional data		
Designation	Circuit as a changeover	Circuit as an NC contact	Silver	Gold (PLC-Application)	Snap action switch	Push action switch	Cable: with wires 0,75 mm ²	Utilization category acc. to IEC 60947	Conventional thermal current I th	Rated Insulation Voltage Ui	Short circuit protection	Mechanical Lifetime	Positive opening acc. to EN 60947-5-1 Annex K	Operating Temperature
EX	•		•		•		•	AC-15: 400V, 2A DC-13: 250V, 0,15A	5A	400V	*1	2x106		-40°C ... +60°C *
EXZ		•	•			•	•	AC-15: 400V, 2A DC-13: 250V, 0,15A	5A	400V	*1	2x106	•	-40°C ... +60°C

* 1) The short-circuit protection for the EX and EXZ contacts must be designed according to the information in the EC Type Examination and the output of the user.

Switches for device category 3D: All standard switches (see chapter 3.1.3.13)

Stromag Geared Cam Limit Switches

Limit Switch Control Current

Series 100 / 110 – Encoder device

Revision number: 3.1.3.21-01

Revision date: 19.11.2019

Features

- Additional housing for installation of special hollow shaft multiturn encoders

Application

- Cranes

Additional information

- No standard application. Please contact our Product Management Department info@stromag.com

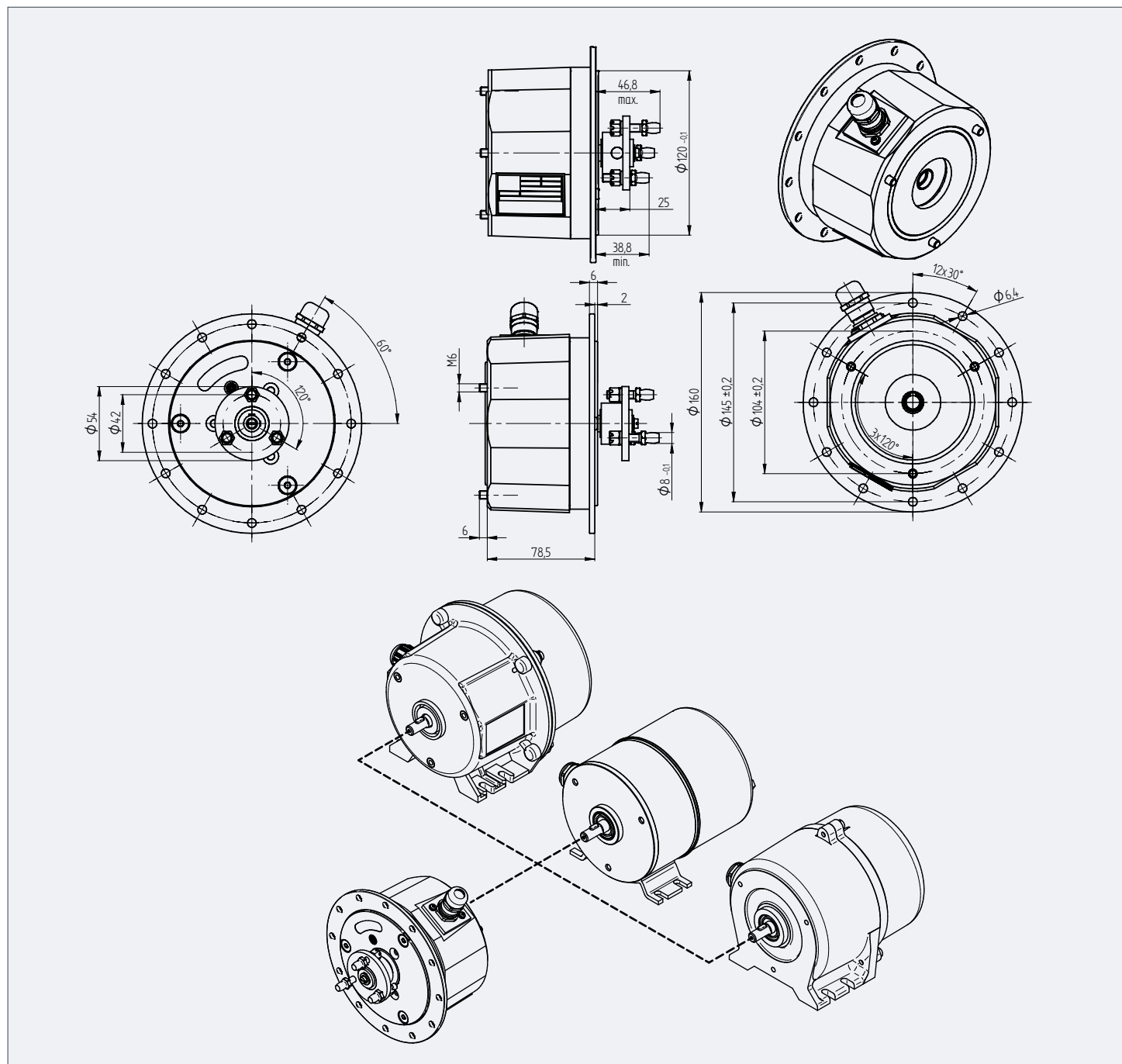

Stromag Geared Cam Limit Switches

Limit Switch Control Current

Series 100 / 110 – Option: Analog Encoder

Revision number: 3.1.3.22-01

Revision date: 19.11.2019

Features

- Singleturn absolute encoder up to 12 Bit
- Turns synchronously with the cam discs

Application

- For measurement of the absolute position

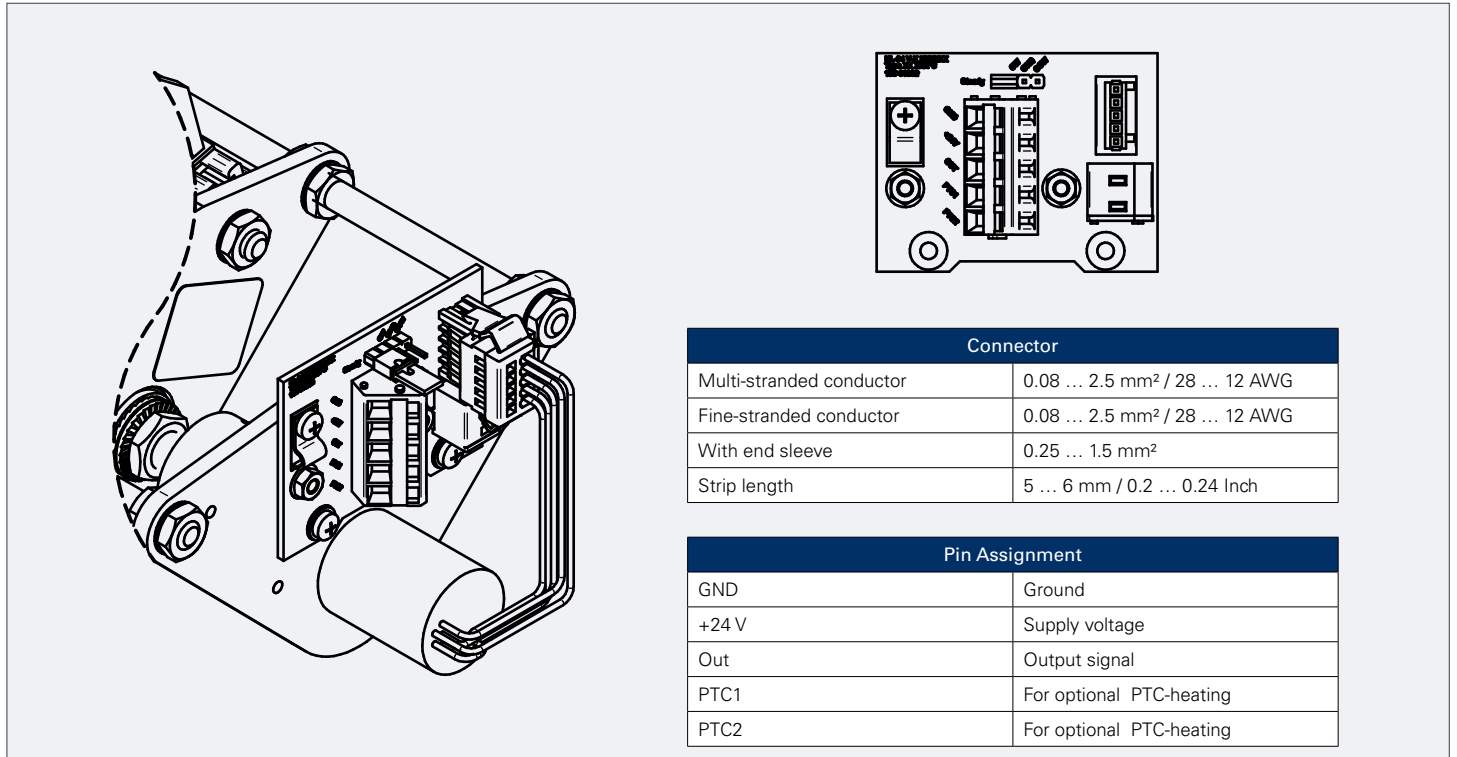

Connector	
Multi-stranded conductor	0.08 ... 2.5 mm ² / 28 ... 12 AWG
Fine-stranded conductor	0.08 ... 2.5 mm ² / 28 ... 12 AWG
With end sleeve	0.25 ... 1.5 mm ²
Strip length	5 ... 6 mm / 0.2 ... 0.24 Inch

Pin Assignment	
GND	Ground
+24 V	Supply voltage
Out	Output signal
PTC1	For optional PTC-heating
PTC2	For optional PTC-heating

Technical data	Current output		Voltage output	
	Current output	Voltage output	Current output	Voltage output
Drive	Coupling „N“ (1:1 with cam discs)	Coupling „N“ (1:1 with cam discs)	Coupling „N“ (1:1 with cam discs)	Coupling „N“ (1:1 with cam discs)
Measuring range*	360°	360°	360°	360°
Output Signal	4 ... 20 mA	0 ... 10 V	4 ... 20 mA	0 ... 10 V
Turning direction	programmable	programmable	programmable	programmable
Resolution	14 Bit	14 Bit	14 Bit	14 Bit
Indep. Linearity	± 0.1 % of measuring range	± 0.1 % of measuring range	± 0.1 % of measuring range	± 0.1 % of measuring range
Supply Voltage	18 ... 35 V DC	18 ... 35 V DC	18 ... 35 V DC	18 ... 35 V DC
Current consumption without load (typ.)	20 mA	20 mA	20 mA	20 mA
Ohmic load at output	0 ... 500 Ohm	> 10 kOhm	0 ... 500 Ohm	> 10 kOhm
Max. capacitive load at output	100 nF	100 nF	100 nF	100 nF
Lifetime	360 mio. movements	360 mio. movements	360 mio. movements	360 mio. movements
Operating Temperature	-40°C ... +85 °C	-40°C ... +85 °C	-40°C ... +85 °C	-40°C ... +85 °C

Stromag Geared Cam Limit Switches

Limit Switch Control Current

Series 100 / 110 – Option: Incremental Encoder

Revision number: 3.1.3.23-02

Revision date: 14.06.2021

Features

- Up to 3600 increments available
- Turns synchronously with the drive shaft

Application

- For measuring of position and speed

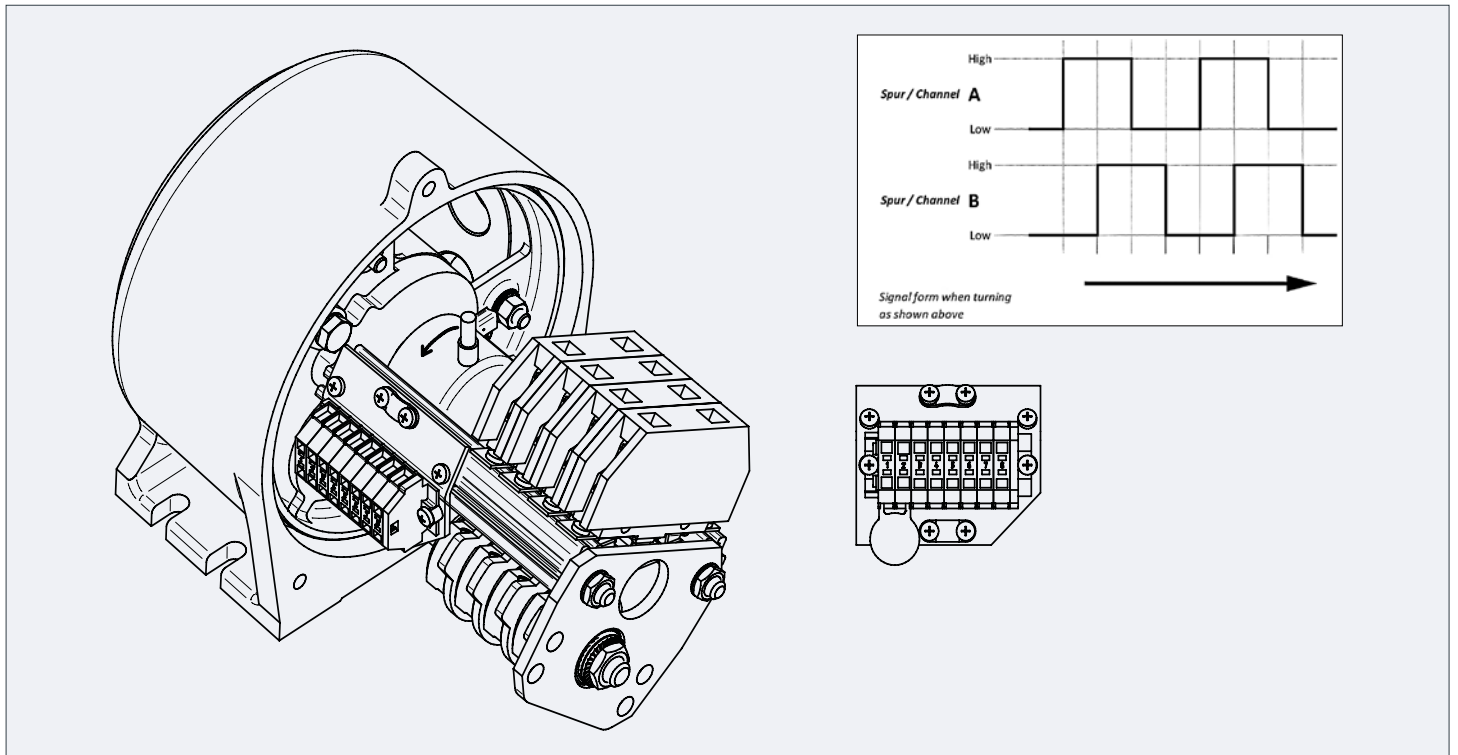

Technical Data	RS422	Push-Pull
Power Supply UB	5 V ± 5% or 8...30 V	8 ... 30 V DC
Pulses / 360°	5 ... 3600	
Power consumption (without load)	Typ. 40 mA Max. 90 mA	< 40 mA
Permissible load	± 20 mA	± 50 mA
Signal level „high“	> 2,5 V	> Vcc - 3 V
Signal level „low“	< 0,5 V	< 2,5 V
Max. frequency	300 kHz	200 kHz
Operating temperature	-40°C ... +85 °C (5...1024 pulses)	
	-30°C ... +85 °C (>1024 pulses)	

Assignment	Pin	Color
Ground	1	white
Supply-Voltage VCC	2	brown
A - Signal	3	green
B - Signal	4	yellow
0 - Signal	5	gray
A-Inv. - Signal	6	pink
B-Inv. - Signal	7	blue
0-Inv. - Signal	8	red

