

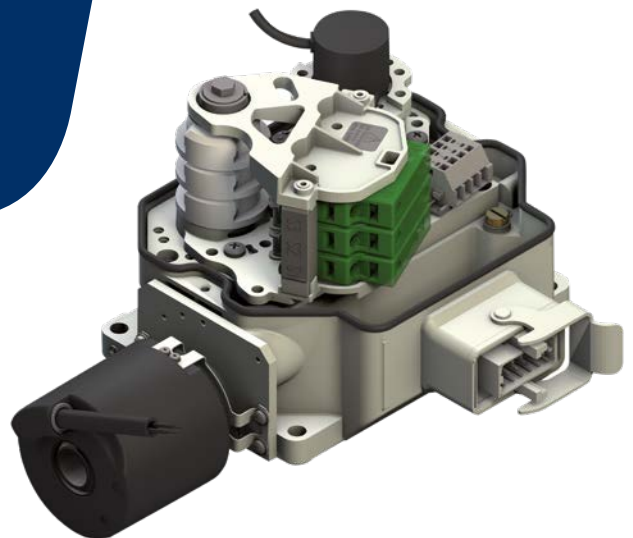

**SERIES LIGHT CAM[®]
AND LIGHT CAM[®] M**
GEARED CAM LIMIT SWITCHES



Stromag

Founded in 1932, Stromag has grown to become a globally recognized leader in the development and manufacture of innovative power transmission components for industrial drivetrain applications. Stromag engineers utilize the latest design technologies and materials to provide creative, energy-efficient solutions that meet their customer's most challenging requirements.

Stromag's extensive product range includes flexible couplings, disc brakes, limit switches, an array of hydraulically, pneumatically, and electrically actuated brakes, and a complete line of electric, hydraulic and pneumatic clutches.

Stromag engineered solutions improve drivetrain performance in a variety of key markets including energy, off-highway, metals, marine, transportation, printing, textiles, and material handling on applications such as wind turbines, conveyor systems, rolling mills, agriculture and construction machinery, municipal vehicles, forklifts, cranes, presses, deck winches, diesel engines, gensets and stage machinery.



CONTENT

Catalog Series Light Cam® and Light Cam® M: II

At a Glance	04
Series Light Cam®/Light Cam® M – Basic Limit Switch	05
Series Light Cam®/Light Cam® M – Gear Data	06
Series Light Cam®/Light Cam® M – Switching Contacts 99	07
Series Light Cam®/Light Cam® M – Switching Contacts 80-90	08
Series Light Cam® – Light Cam® B3	09
Series Light Cam® – Light Cam® B5	10
Series Light Cam® – Light Cam® Metal B3	11
Series Light Cam® – Light Cam® Metal B5	12
Light Cam®/Light Cam® M – Customizable Cam Discs	13
Light Cam®/Light Cam® M – Optional Drive Flanges	14
Light Cam®/Light Cam® M – Option: Anti-Condensation-Heating	15
Light Cam®/Light Cam® M – Option: Potentiometer	16
Light Cam®/Light Cam® M – Option: Analog Encoder 4-20 mA	17
Light Cam®/Light Cam® M – Option: Incremental Encoder	18
Light Cam®/Light Cam® M – Option: SSI Multiturn Encoder	19
Light Cam®/Light Cam® M – Option: CANopen Multiturn Encoder	20
Light Cam®/Light Cam® M – Option: Internal Profinet Encoder	21
Light Cam®/Light Cam® M: 2 nd shaft end (encoder drive)	22
Light Cam®/Light Cam® M: Key of Types	23
Light Cam®/Light Cam® M: Highly Customizable Solutions	24

Stromag Geared Cam Limit Switches

AT A GLANCE

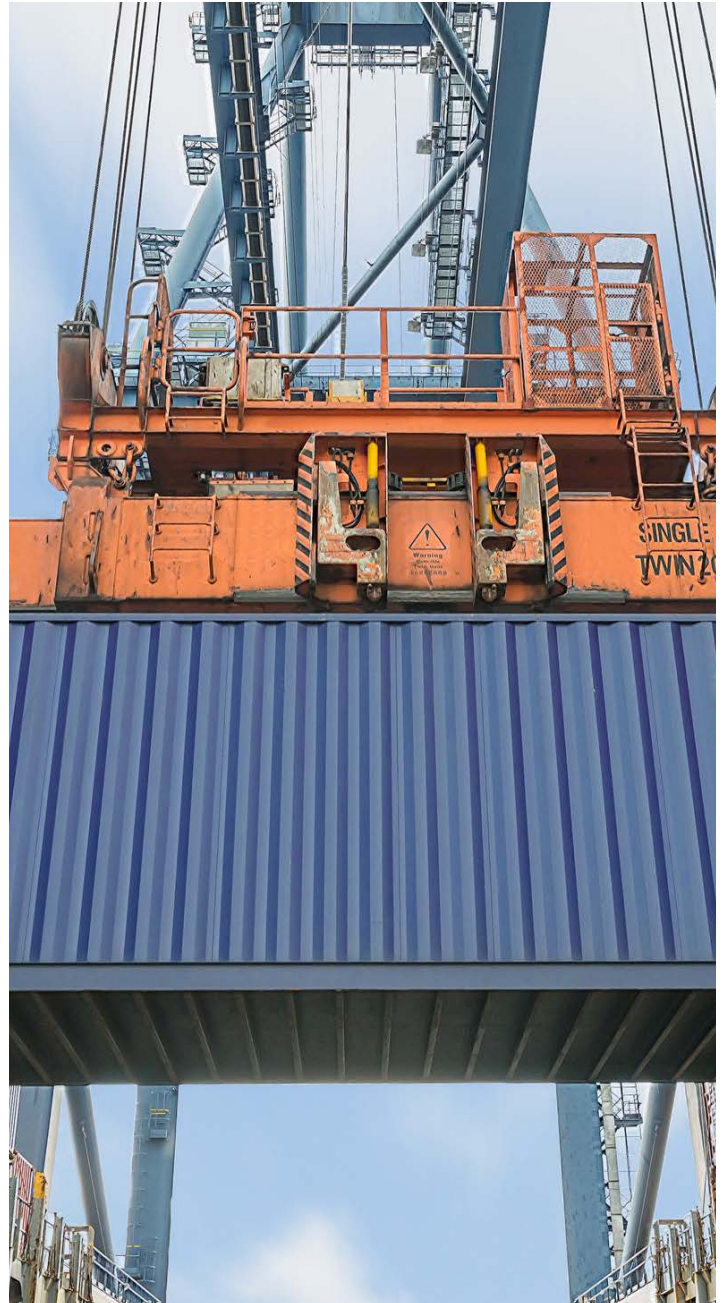

LIGHT CAM[®] AND LIGHT CAM[®] M

BENEFITS INCLUDE

- Form fit gear
- Self locking design for the cam discs
- High gear ratio of 74 for adjusting the cams
- Drive of incremental and absolute encoders possible
- Operating temperature: -40 °C up to + 80°C

Stromag Geared Cam Limit Switches

Limit Switch Control Current

Worm / Bevel Geared Cam Limit Switches

Series LC[®] / LC[®] M – Basic Limit Switch

Revision number: 3.1.2.1-01

Revision date: 19.11.2019

Features

- Combined worm / spur gear for high gear reductions requiring less mounting space
- 4 or 8 contacts available

Application

- Crane
- Wind
- Stage

Additional information

- IP65 synthetic housing or IP66 aluminum housing available

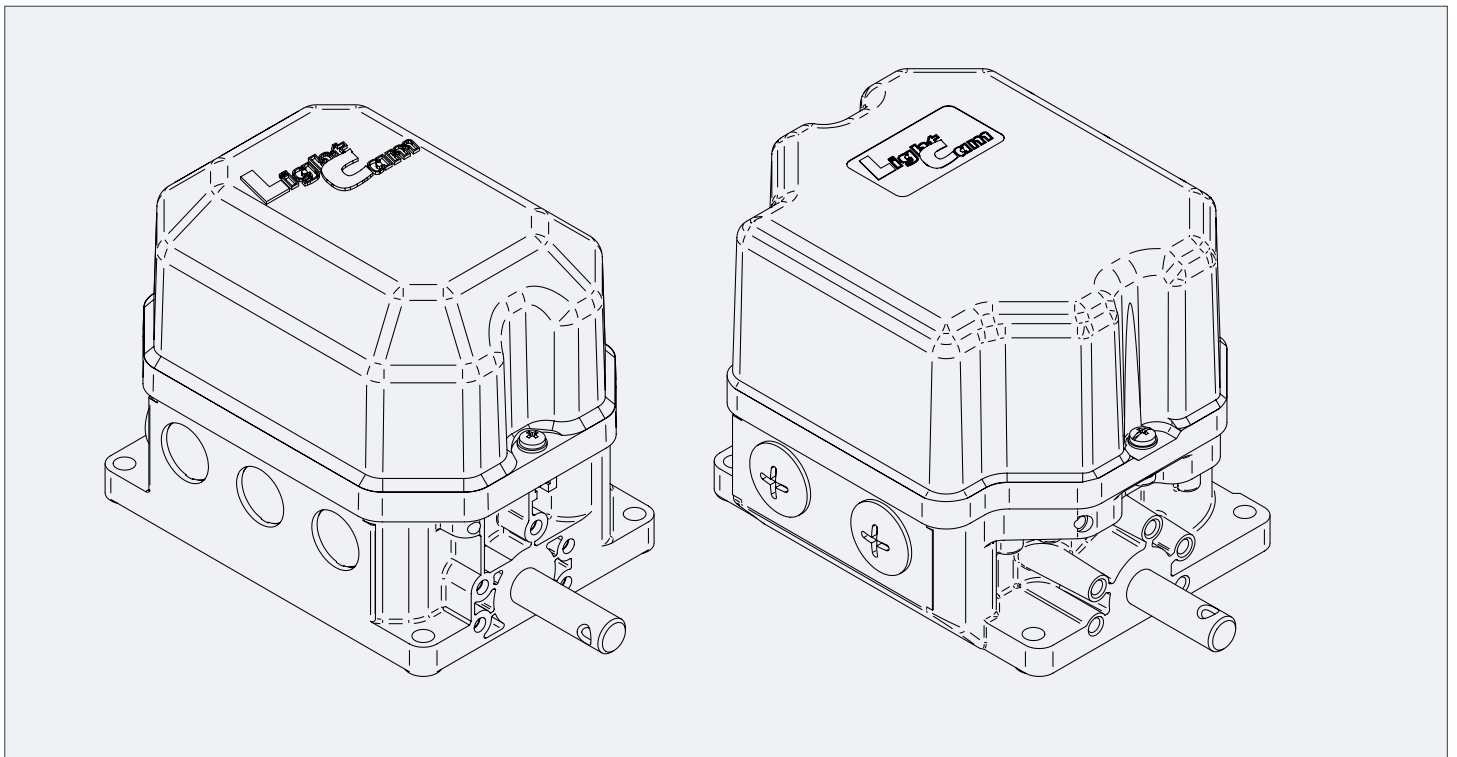

Stromag Geared Cam Limit Switches

Limit Switch Control Current

Worm / Bevel Geared Cam Limit Switches

Series LC[®] / LC[®] M – Gear Data

Revision number: 3.1.2.2-01

Revision date: 19.11.2019

Features

- Cam discs with precise adjustment and cam diameter of 42.5 mm
- Form fit gear design

Additional information

- Self-locking design for the cam discs
- High gear ratio of 74 for the cam adjustment

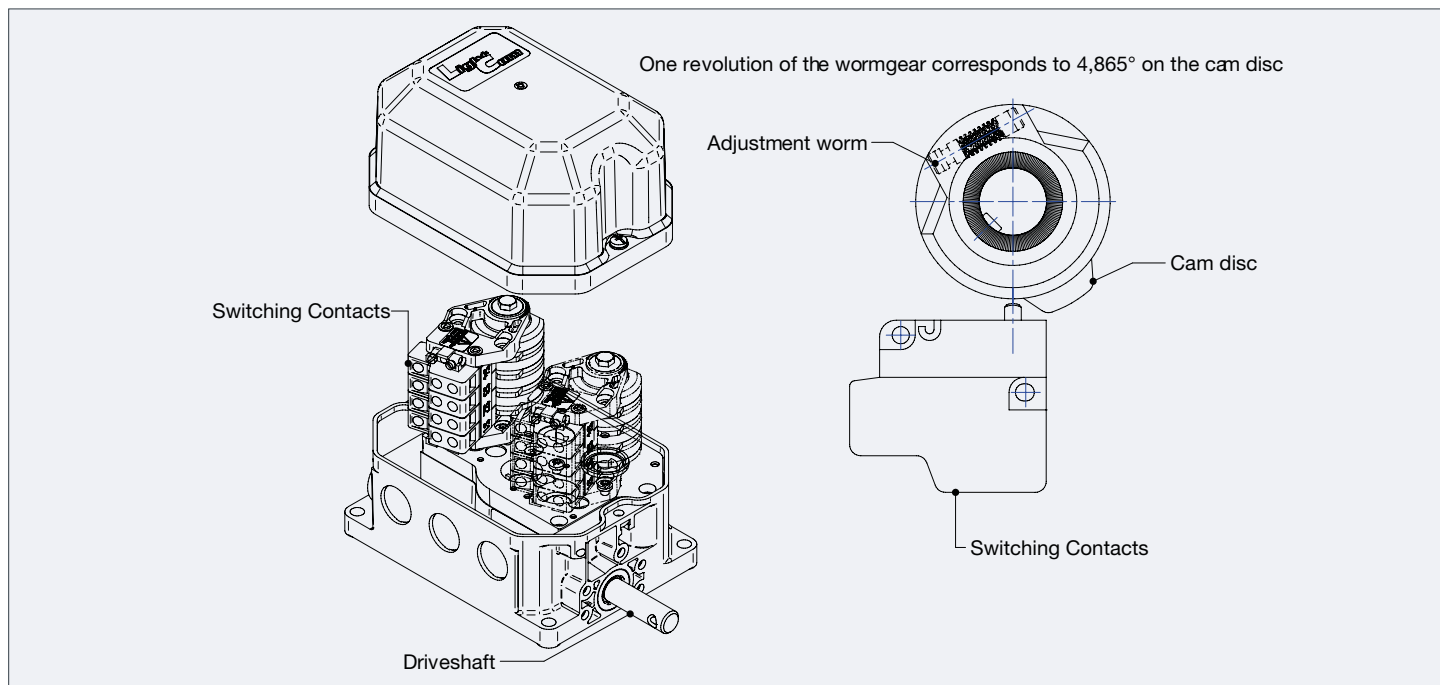

Gear Data Light Cam[®] / Light Cam[®] M

Nominal revolutions at 40° - cam disc	Gear ratio	Mechanical hysteresis [revolutions at drive shaft]		Min. drive torque [Nm] for Switching an single contact	Max. drive torque [Nm] for forced opening Switching an single contact		Max. input speed [rpm]	Min. input speed [rpm] (only when used as a change-over)			
		Contact			Contact			Contact			
		99, 99G	80, 88, 90, 90G		99, 99G	80, 88, 90, 90G		99, 99G	90, 90G	88	80
0,85	1,000	0,003	0,017	0,2	0,493	1,663	200	0,049	0,212	0,042	0,424
1,85	2,118	0,006	0,037		0,338	0,891		0,103	0,449	0,090	0,899
3,9	4,484	0,013	0,077		0,265	0,526		0,219	0,952	0,190	1,903
6	6,781	0,020	0,117		0,243	0,416		0,331	1,439	0,288	2,878
9	10,254	0,031	0,177		0,229	0,343		0,501	2,176	0,435	4,352
15	16,994	0,051	0,294		0,217	0,286		0,830	3,606	0,721	7,212
25	29,672	0,089	0,513		0,210	0,249		1,449	6,297	1,259	12,593
29	33,529	0,101	0,579		0,209	0,244		1,638	7,115	1,423	14,230
53	60,000	0,180	1,037		0,205	0,224		2,931	12,732	2,546	25,465
76	85,500	0,257	1,477		0,203	0,217		4,176	18,144	3,629	36,287
95	107,368	0,322	1,855		0,203	0,214	5,244	22,784	4,557	45,569	
135	153,000	0,459	2,644		0,202	0,210	7,473	32,468	6,494	64,935	
180	208,772	0,626	3,607		0,201	0,207	10,198	44,303	8,861	88,606	
260	297,500	0,893	5,140		0,201	0,205	14,532	63,131	12,626	126,263	
305	343,817	1,031	5,940		0,201	0,204	16,794	72,960	14,592	145,920	
360	406,870	1,221	7,030		0,201	0,204	19,874	86,340	17,268	172,681	
435	489,939	1,470	8,465		0,201	0,203	23,931	103,968	20,794	207,937	
515	579,789	1,739	10,017		0,201	0,203	28,320	123,035	24,607	246,070	
620	698,163	2,094	12,063		0,200	0,202	34,102	148,155	29,631	296,310	
880	994,880	2,985	17,189		0,200	0,201	48,595	211,120	42,224	422,240	

Stromag Geared Cam Limit Switches

Limit Switch Control Current

Worm / Bevel Geared Cam Limit Switches

Series LC[®]/ LC[®] M – Switching Contacts 99

Revision number: 3.1.2.3-02

Revision date: 31.03.2022

Features

- Contacts with positive opening
- For up to 10 million switching operations
- Gold plated contacts on request
- Push or snap action contacts

Application

- Silver contacts for Relais
- Gold contacts for PLC

Additional information

- Screw or flat plug connections

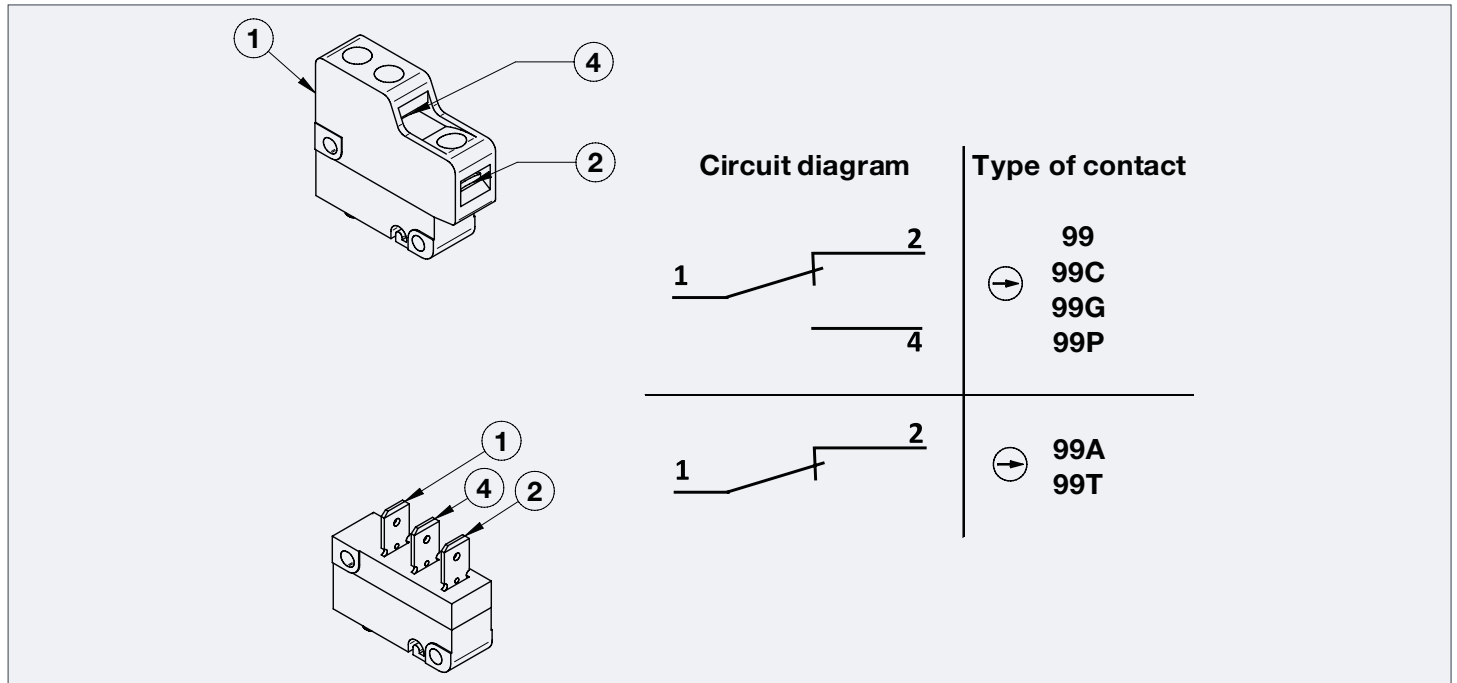

Switching contact		Contact material		Switching system		Connection			Functionality		Electrical data			
Designation	Change-Over (NC/NO)	Normally closed (NC)	Silver	Gold (PLC-Application)	Snap-action	Push-action	screw terminals; 0,5 - 1,5 mm ² / AWG 16 ... 22	Flatplugs 6,3mm	Standard wire output	Positive opening acc. to EN 60947-5-1 Annex K	Short circuit protection	Utilization category acc. to IEC 60947	Conventional thermal current I _{th}	Rated Insulation Voltage U _i
99	•		•		•		•			•	10A gG	AC-15: 1,5A, 230V DC-13: 0,5A, 60V	10A	250V
99P	•		•		•				•	10A gG				
99G	•			•	•				•	2A gR				
99T		•	•			•	•		•	10A gG				
99A		•		•		•	•		•	2A gG				
99C	•		•		•			•	•	10A gG				

Stromag Geared Cam Limit Switches

Limit Switch Control Current

Worm / Bevel Geared Cam Limit Switches

Series LC®/ LC® M – Switching Contacts 80 – 90

Revision number: 3.1.2.3-01

Revision date: 19.11.2019

Features

- Snap – and push action contacts available in silver and gold
- Galvanic isolated contacts possible
- All contacts with positive opening

Application

- Silver contacts for relays
- Gold contacts for PLC

Additional information

- Up to 3 contacts can be installed inside

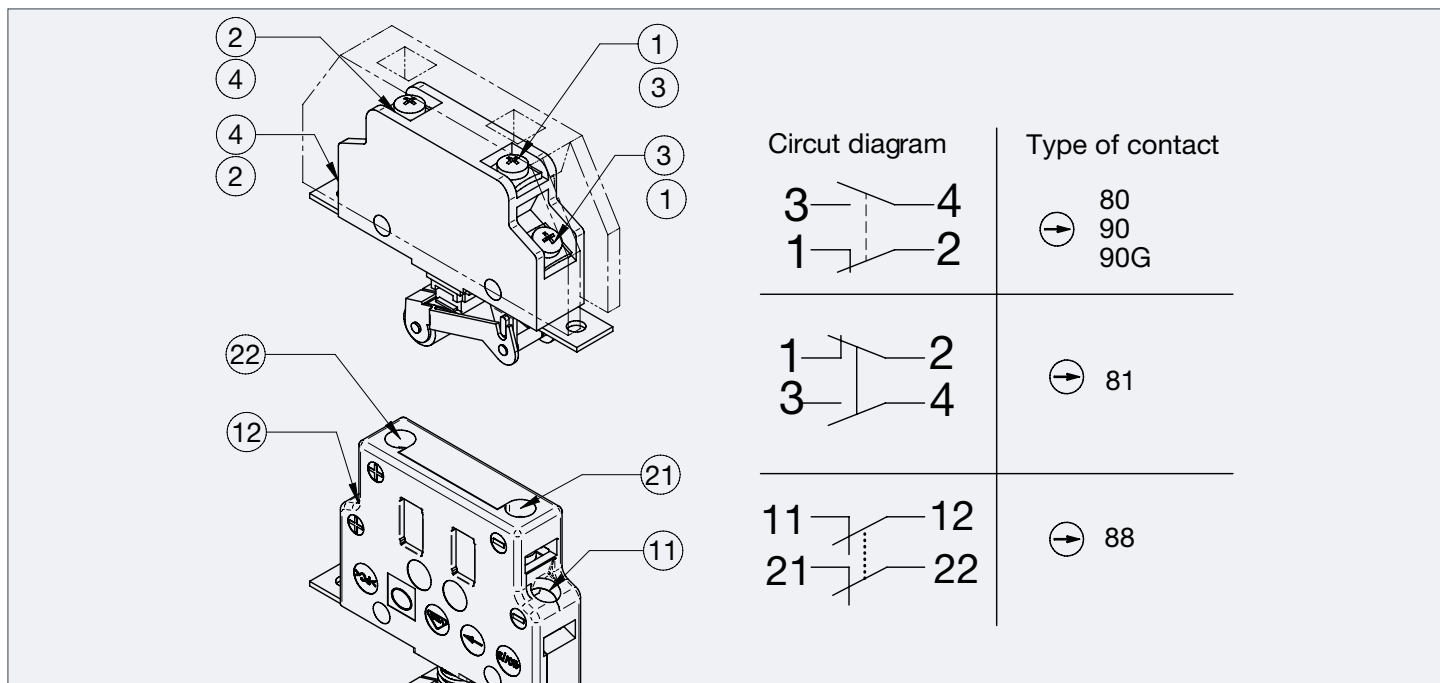

Switching contact			Contact material		Switching system		Connection	Functionality			Electrical data		
Designation	Change-Over (NC / NO)	Normally closed (NC)	Silver	Gold (PLC-Application)	Snap-action	Push-action	screw terminals; 0,75 - 2,5 mm ² / AWG 14 ... 20	Positive opening acc. to EN 60947-5-1 Annex K	Short circuit protection	Utilization category acc. to IEC 60947	Conventional thermal current I _{th}	Rated Insulation Voltage U _i	
80	•		•		•		•	•	6A gG	AC-15: 3A, 230V DC-13: 1A, 110V	10A	400V	
81	•		•			•	•	6A gG	AC-15: 3A, 230V DC-13: 1A, 110V				
90	•		•		•		•	6A gR	AC-15: 1A, 230V DC-13: 0,5A, 110V				
90G	•			•	•		•	2A gG	AC-12: 0,25A, 230V DC-12: 0,25A, 110V				
88		•		•	•		•	10A gG	AC-15: 1,5A, 230V DC-13: 1,5A, 24V				

Stromag Geared Cam Limit Switches

Limit Switch Control Current

Worm / Bevel Geared Cam Limit Switches

Series LC[®] – Light Cam[®] B3

Revision number: 3.1.1.4-01

Revision date: 19.11.2019

Features

- Synthetic housing IP65 for outdoor application

Application

- Crane
- Wind
- Stage

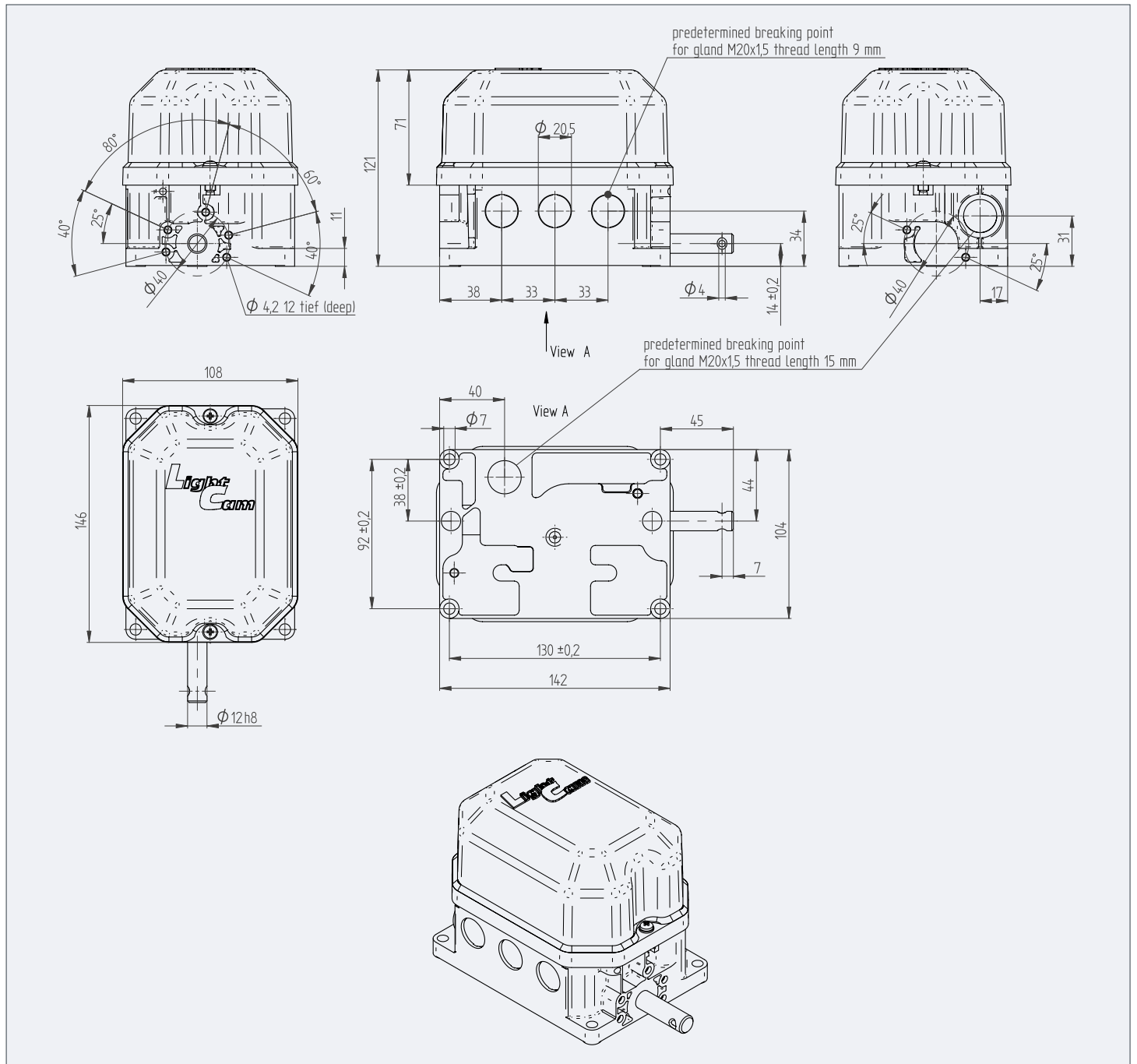

Stromag Geared Cam Limit Switches

Limit Switch Control Current

Worm / Bevel Geared Cam Limit Switches

Series LC[®] – Light Cam[®] B5

Revision number: 3.1.2.5-01

Revision date: 19.11.2019

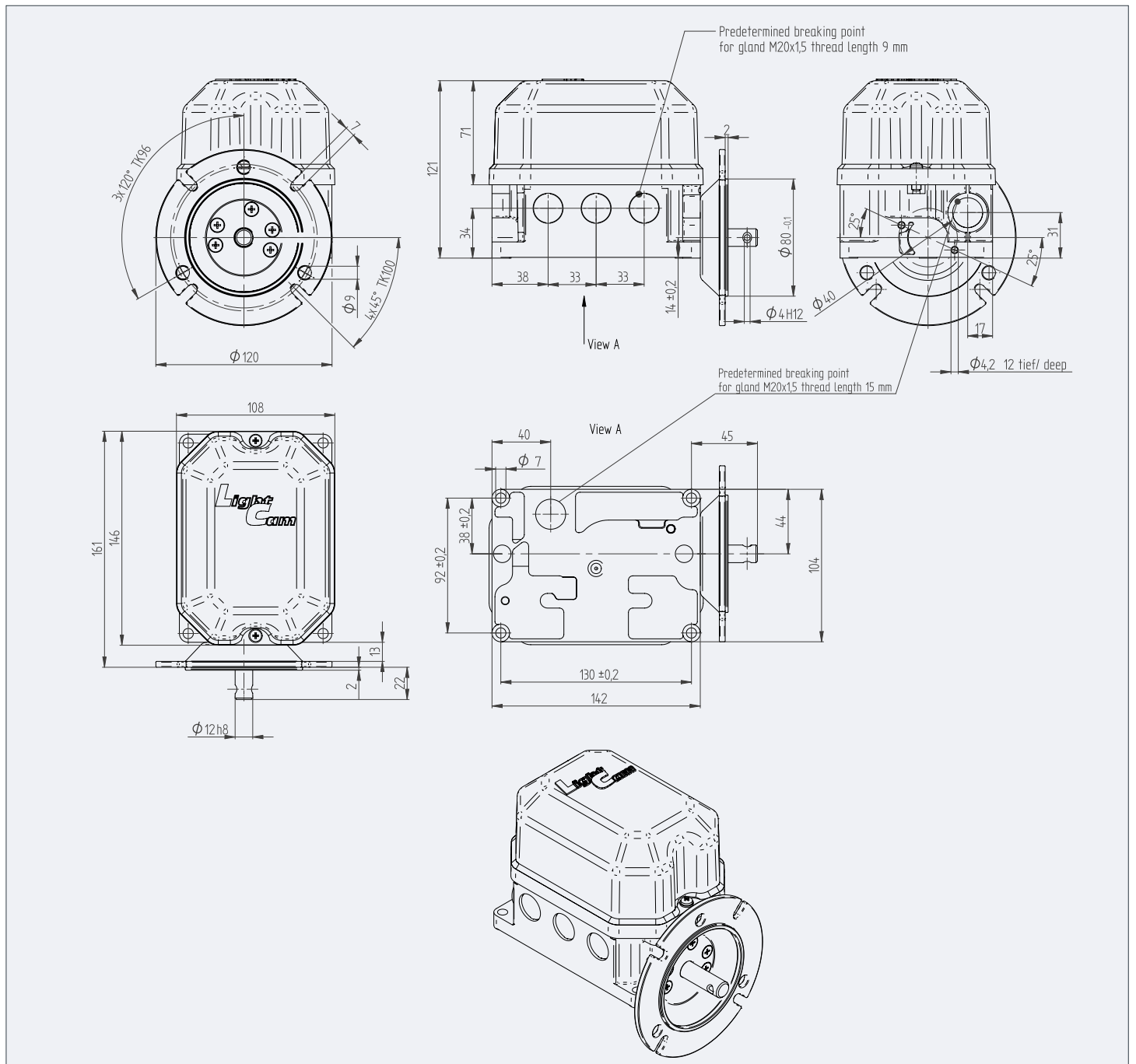

Stromag Geared Cam Limit Switches

Limit Switch Control Current

Worm / Bevel Geared Cam Limit Switches

Series LC[®] – Light Cam[®] Metal B3

Revision number: 3.1.2.6-02

Revision date: 28.10.2022

Features

- Robust aluminum housing protection IP66

Application

- Crane
- Wind

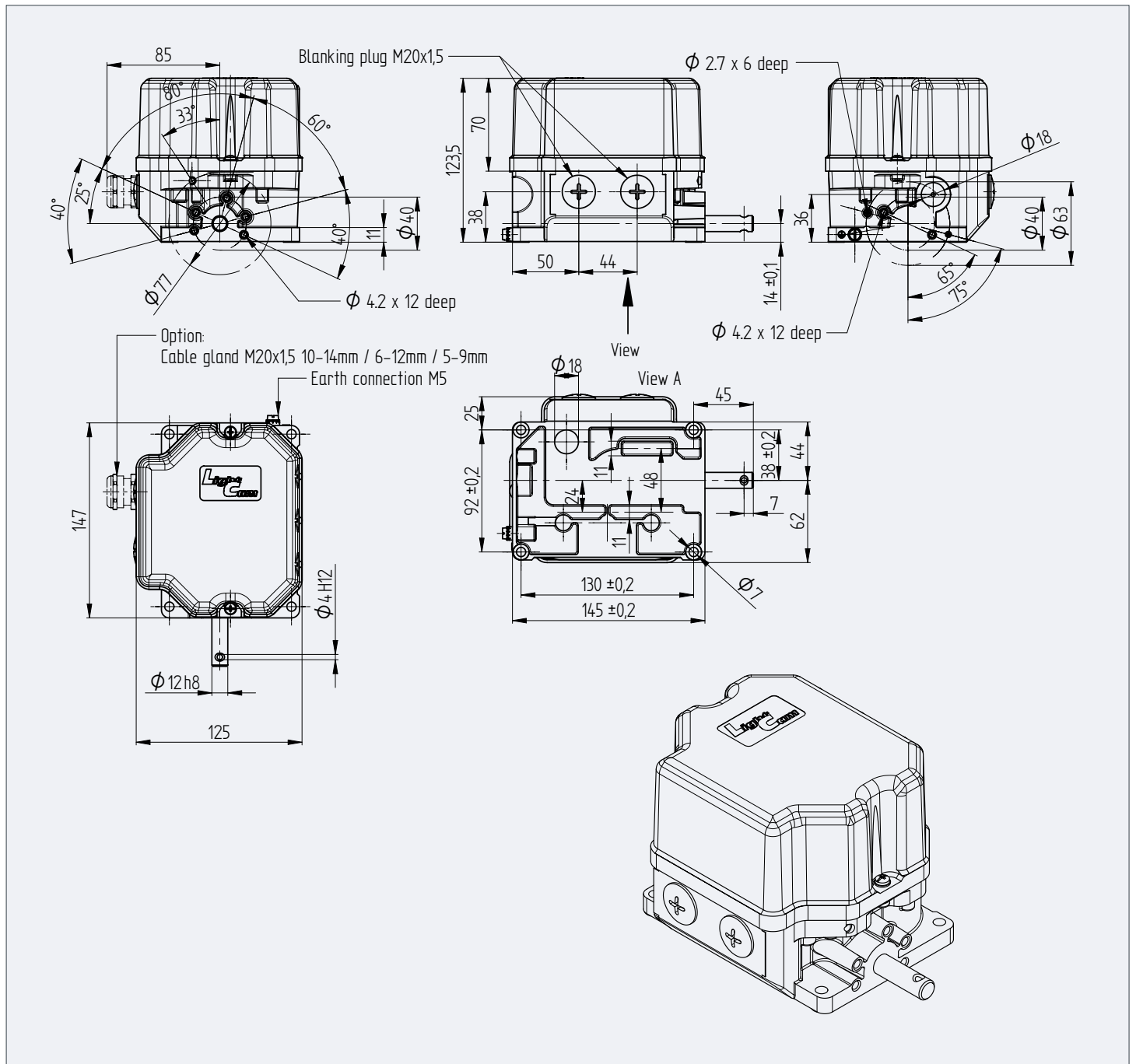

Stromag Geared Cam Limit Switches

Limit Switch Control Current

Worm / Bevel Geared Cam Limit Switches

Series LC[®] – Light Cam[®] Metal B5

Revision number: 3.1.2.7-02

Revision date: 28.10.2022

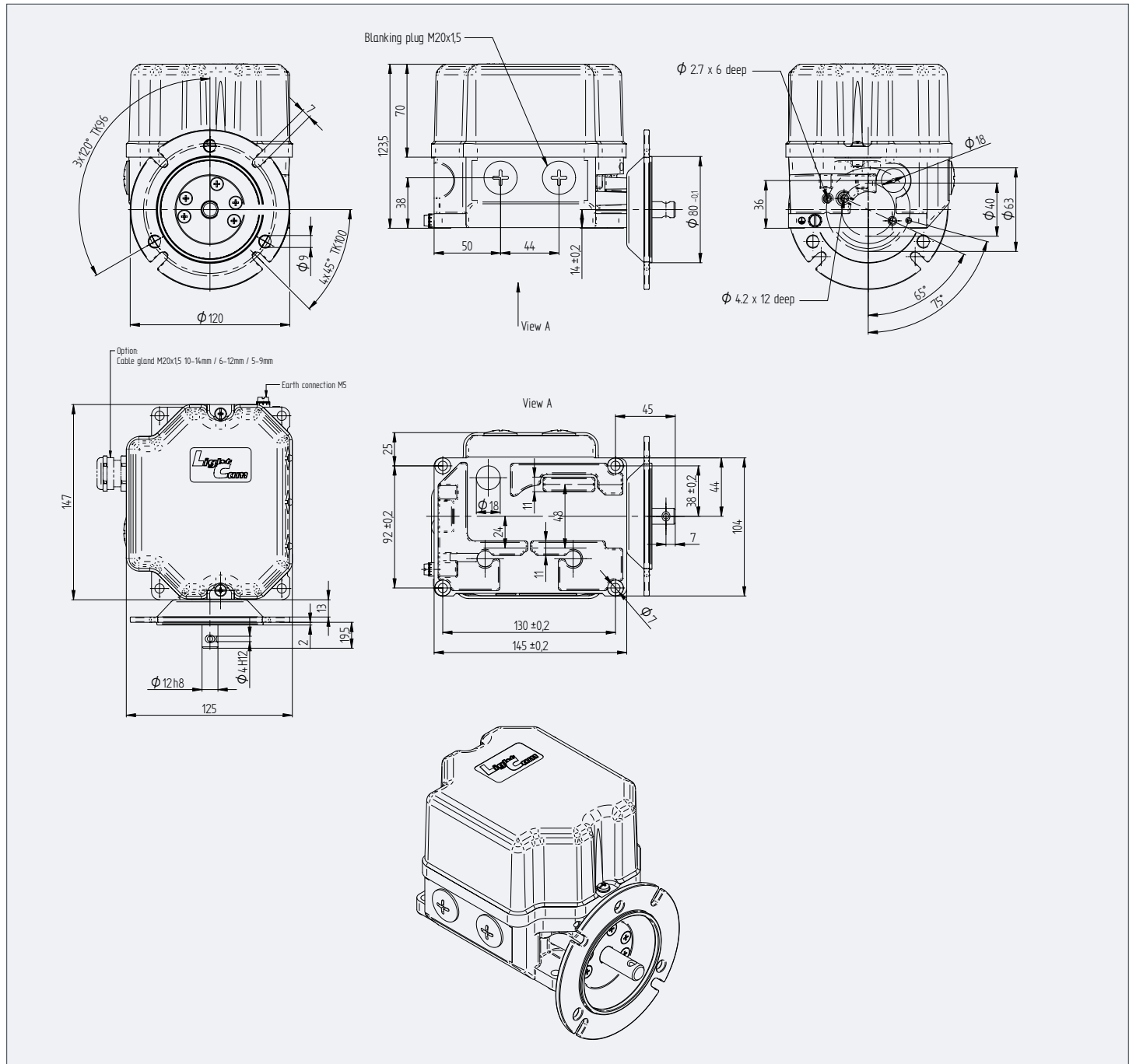

LC[®] / LC[®] M – Customizable Cam Discs

Revision number: 3.1.2.8-01

Revision date: 19.11.2019

Features

- 40 degree cam discs standard
- Other cam angles on request

Application

- For different switching programs cam discs with customized angles can be manufactured

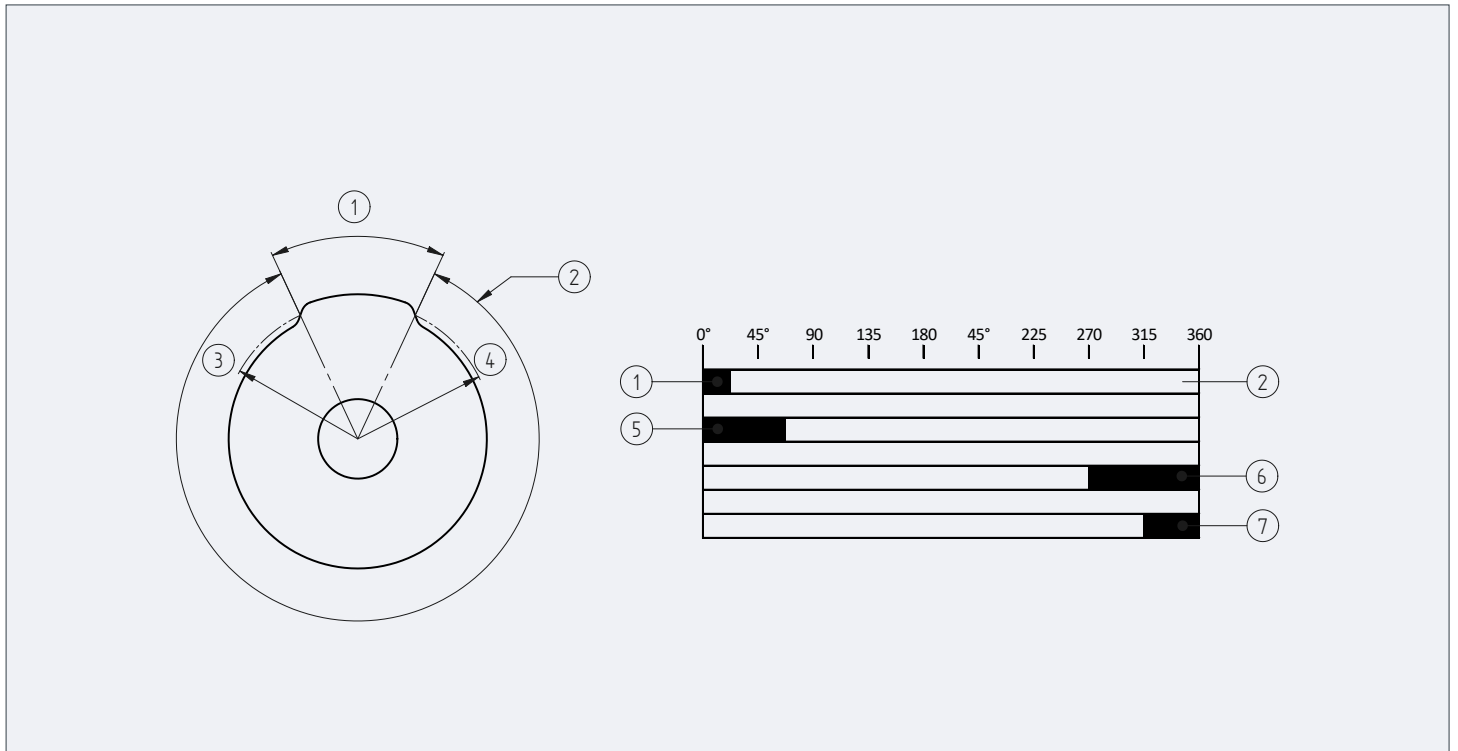

A Cam angle diagram

1 Effective cam angle α (=castor angle)

2 Effective cam angle β

3 Switching point radius

4 Reset point radius

B Application examples

1 Effective cam angle 15°

5 Effective cam angle 60°

6 Effective cam angle 90°

7 Effective cam angle 45°

The cam discs are named after the effective cam angle. For cam discs of series Light Cam[®] / Light Cam[®]M, this corresponds to the switching point angle on the switching point radius of the cam disc. Standard cam angle for series Light Cam[®] / Light Cam[®]M is 40°.

Any cam angles (15° – 345°) can be supplied as a special design upon request.

The usable revolutions enabled by a cam disc on a GCLS drive shaft, result in the following:

$$U = \frac{\beta \cdot i}{360^\circ} = \frac{(360^\circ - \alpha) \cdot i}{360^\circ} = \frac{\alpha \cdot i}{360^\circ}$$

U = Usable revolutions

α = Effective cam angle

β = Usable cam angle ($\beta = 360^\circ - \alpha$)

i = gear ratio

Stromag Geared Cam Limit Switches

Limit Switch Control Current

Worm / Bevel Geared Cam Limit Switches

LC[®] / LC[®] M – Optional Drive Flanges

Revision number: 3.1.2.9-01

Revision date: 19.11.2019

Features

- Easy adaptation for crane hoist with flange F+M and flat shaft adaptor
- Flange A for pinion wheels and belt drives

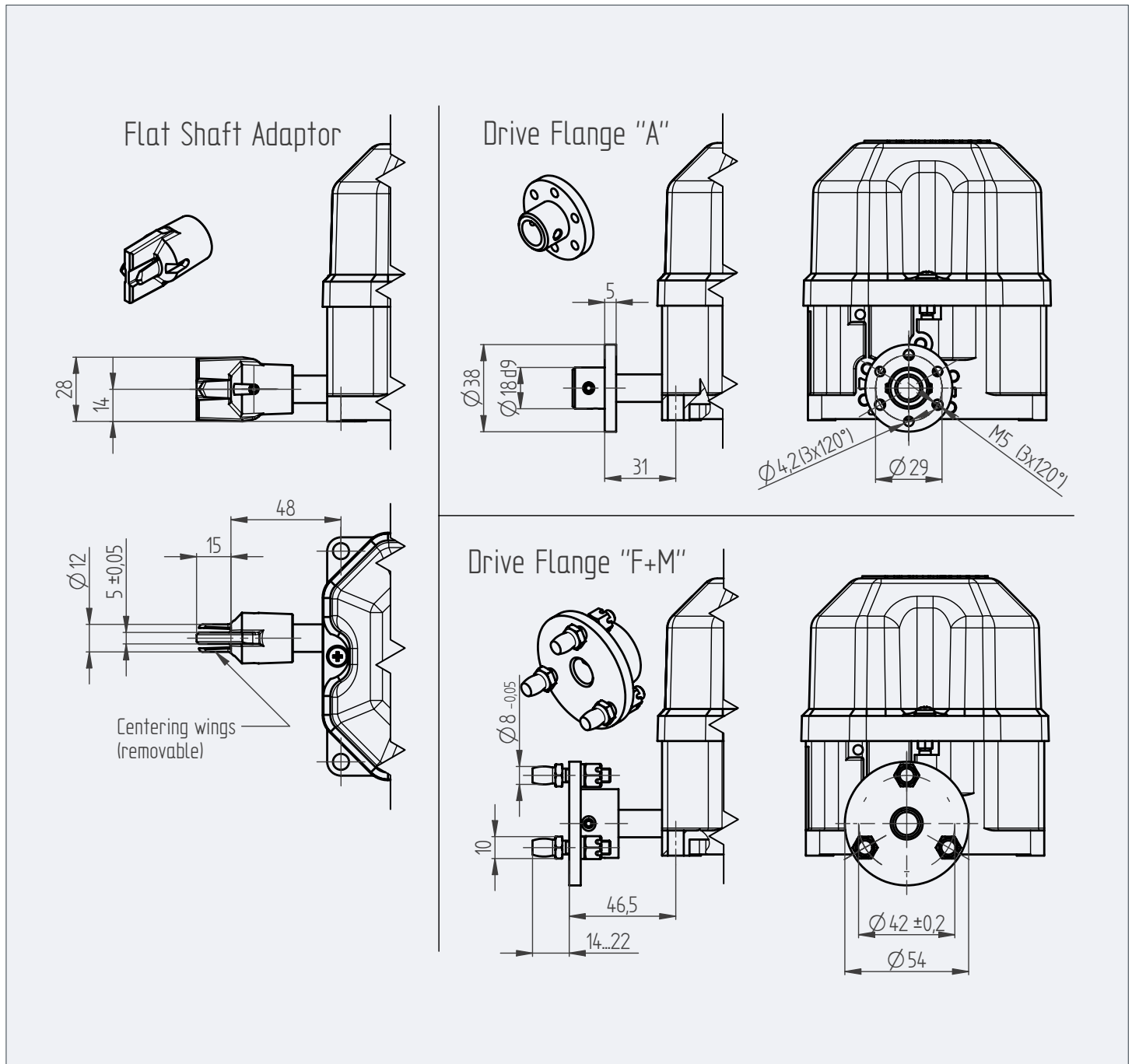

Stromag Geared Cam Limit Switches

Limit Switch Control Current

Worm / Bevel Geared Cam Limit Switches

LC[®] / LC[®] M – Option: Anti-Condensation-Heating

Revision number: 3.1.2.10-02

Revision date: 06.09.2022

Features

- PTC regulated heater
- 12 -36 or 110 – 250 V AC/DC

Application

- For application with high humidity or changing temperatures to avoid condensation water

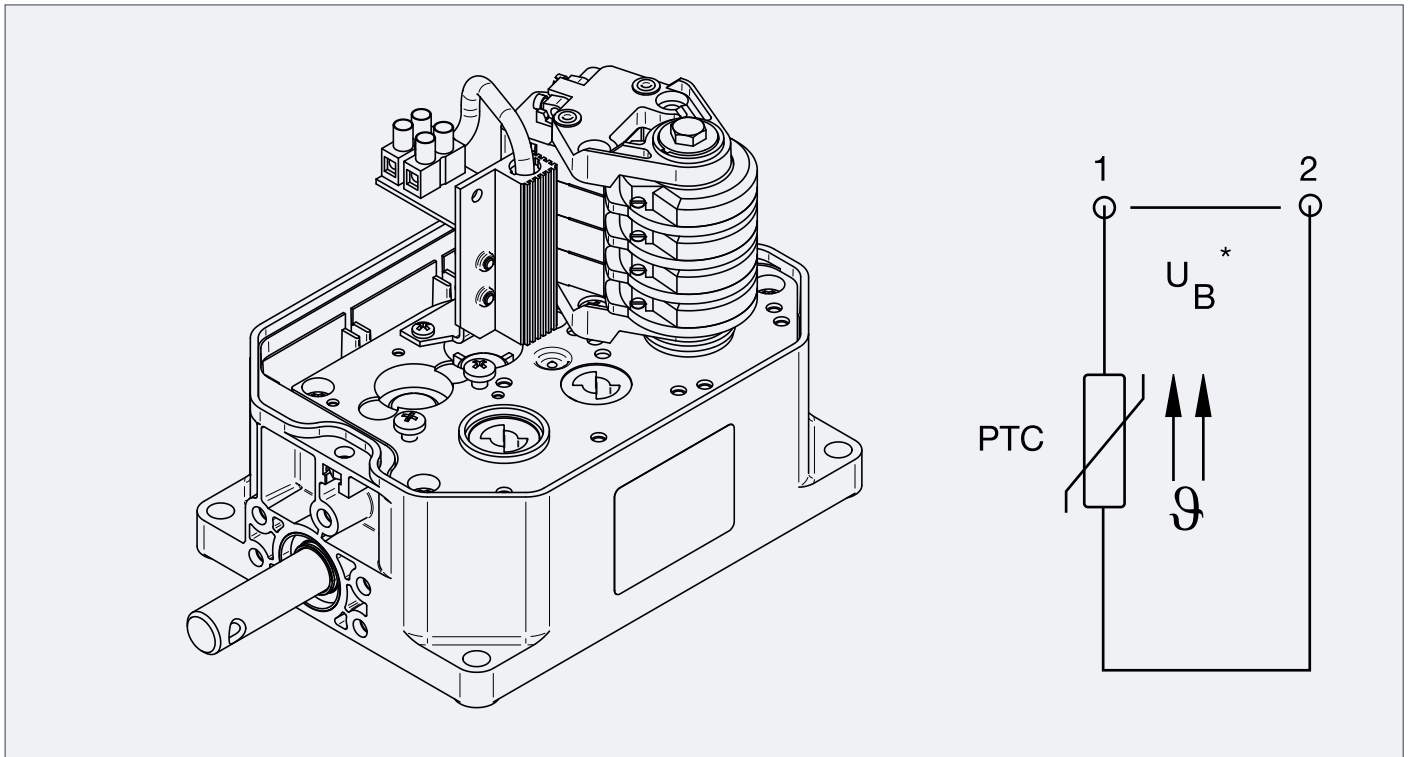

Design: UB	12 – 30 V AC/DC	110 – 250 V AC/DC
Heat Output	ca. 2.5 Watts	ca. 4 Watts
PTC Cooling resistor (at 25 °C)	$R_{25} = 20 \Omega \pm 35 \%$	$R_{25} = 1500 \Omega \pm 35 \%$
PTC Reference temperature	50 °C	50 °C
Protection class (VDE 0100, 0160)	II	II
Connecting cable	2 x 0,25 mm ² , Silicon cable	2 x 0,25 mm ² , Silicon cable
Radiator	Anodised aluminum	Anodised aluminum
Weight	approx. 40 g	approx. 40 g

Stromag Geared Cam Limit Switches

Limit Switch Control Current

Worm / Bevel Geared Cam Limit Switches

LC[®] / LC[®] M – Option: Potentiometer

Revision number: 3.1.2.11-01

Revision date: 19.11.2019

Features

- Cost effective solution for analog measurement

Application

- For simple measurements with lower requirements for preciseness

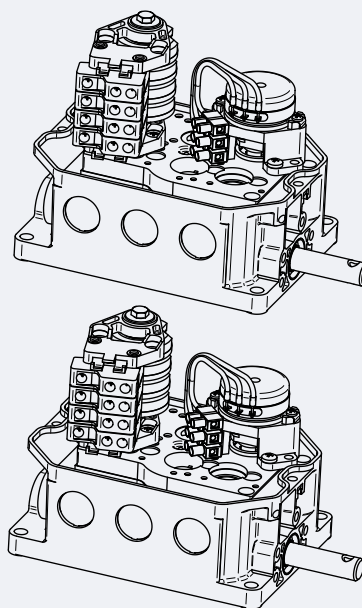
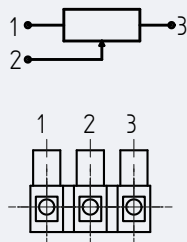

Connector	
Solid conductor	0.5 ... 2.5 mm ² / 20 ... 12 AWG
Fine-stranded conductor	0.5 ... 2.5 mm ² / 20 ... 12 AWG
Strip length	ca. 4 mm / ca. 0.15 Inch

Pin Assignment	
Pin	Color
1	red
2	blue
3	black

Technical data

Technology	wirewound	conductive synthetic						
Effective electrical angle of rotation*	355° ±5°	350° ±2°						
Rotational noise (ENR)	100 Ohm							
Max. / recommended wiper current	35 mA / 2 µA	max. 1 µA						
Power rating @ 70°C	0,5 W							
Insulation Voltage	1000 VAC, 1 min							
Insulation Resistance	1000 Mohm @ 1000 VDC	> 10 Mohm @ 500 V						
Lifetime	1 Mio. rotations (90% el. eff. angle half sine)*	100.000.000 movements*						
Operating temperature range	-20 ... +80 °C	-30 ... +80 °C						
Vibration (IEC 68-2-6, Test Fc)	15g 10..2000Hz x 12h	20g / 5..2000Hz / 0,75 mm						
Shock (IEC 68-2-27, Test Ea)	49g @ 11 ms x 18	50g / 11 ms						
Total resistance [kOhm]	1	2	5	10	20	1	2	5
Resistance tolerance	±3%	±3%	±3%	±3%	±3%	±20%	±20%	±20%
Independent linearity (best straight line)	±0,35%	±0,25%	±0,25%	±0,25%	±0,25%	±0,075%	±0,075%	±0,075%
Number of wire turns	570	740	1000	1270	1670	-	-	-
Theoretical resolution	0,18%	0,14%	0,10%	0,08%	0,60%	0,008°	0,008°	0,008°

* Referring to potentiometer shaft

Stromag Geared Cam Limit Switches

Limit Switch Control Current

Worm / Bevel Geared Cam Limit Switches

LC[®] / LC[®] M – Option: Analog Encoder 4 – 20 mA

Revision number: 3.1.2.12-02

Revision date: 12.10.2021

Features

- Contactless measuring method
- Absolute value acquisition
- Long lifetime
- Turning synchronously with the cam discs

Application

- For simple measuring of absolute signals

Additional information

- Programmable type on request

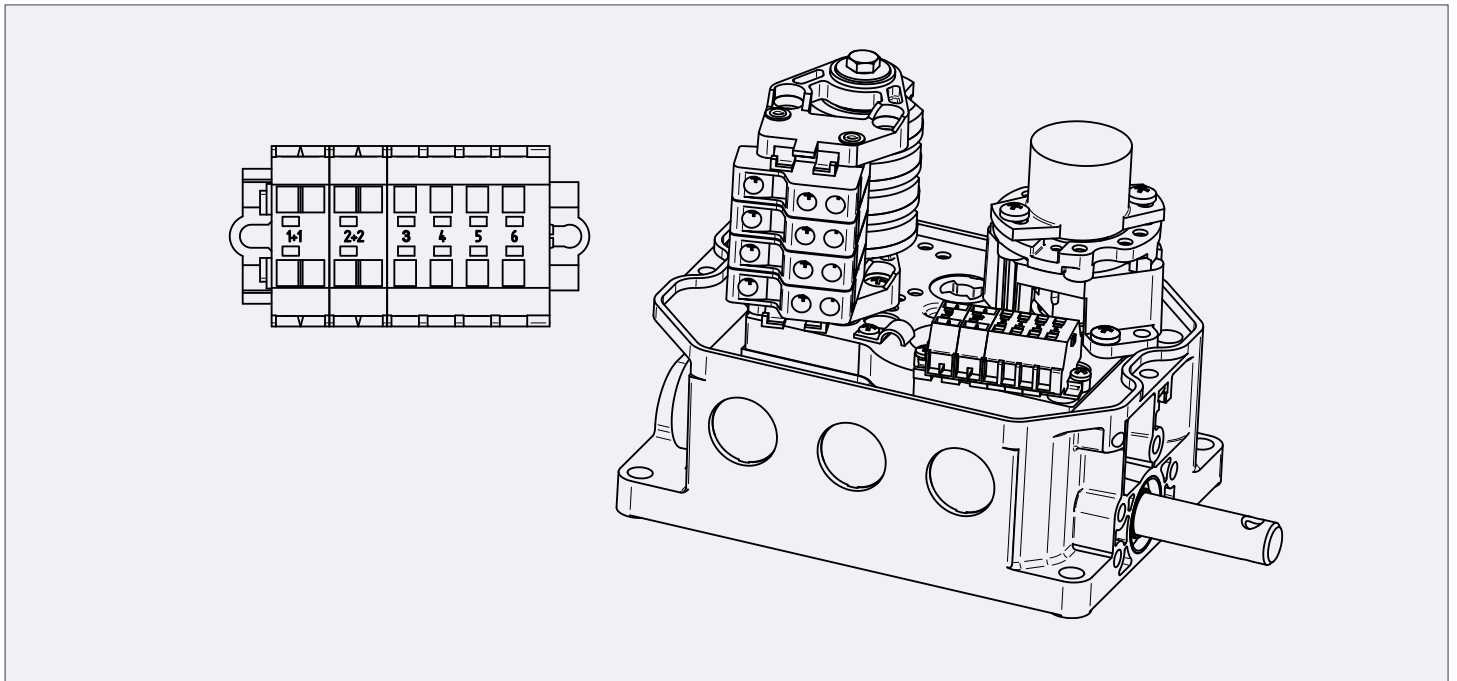

Technical Data	
	non-programmable type
Drive	Coupling (1:1 with cam discs)
Measuring range (Referring to encoder shaft)	360°
Output Signal	4 ... 20 mA
Turning direction (Referring to drive shaft limit switch)	cw rising values
Resolution	12 Bit
Indep. Linearity	± 0.3 % of measuring range
Supply Voltage	16 ... 35 V DC
Current consumption without load (typ.)	19 mA
Ohmic load at output	0 ... 500 Ohm
Max. capacitive load at output	100 nF
Lifetime	50 mio. movements
Operating Temperature	-40°C ... +85 °C

Signal	Pin	Color
Supply Voltage	1+1	brown
Ground	2+2	green
-	3	-
Output signal	4	white
Screen	5	
-	6	-

Stromag Geared Cam Limit Switches

Limit Switch Control Current

Worm / Bevel Geared Cam Limit Switches

LC[®] / LC[®] M – Option: Incremental Encoder

Revision number: 3.1.2.13-01

Revision date: 19.11.2019

Features

- Optical measuring
- Up to 3600 increments in small housing possible
- Already wired to squirrel cage tension

Application

- For giving information about speed and position

Additional information

- Driven 1:1 by bevel gear

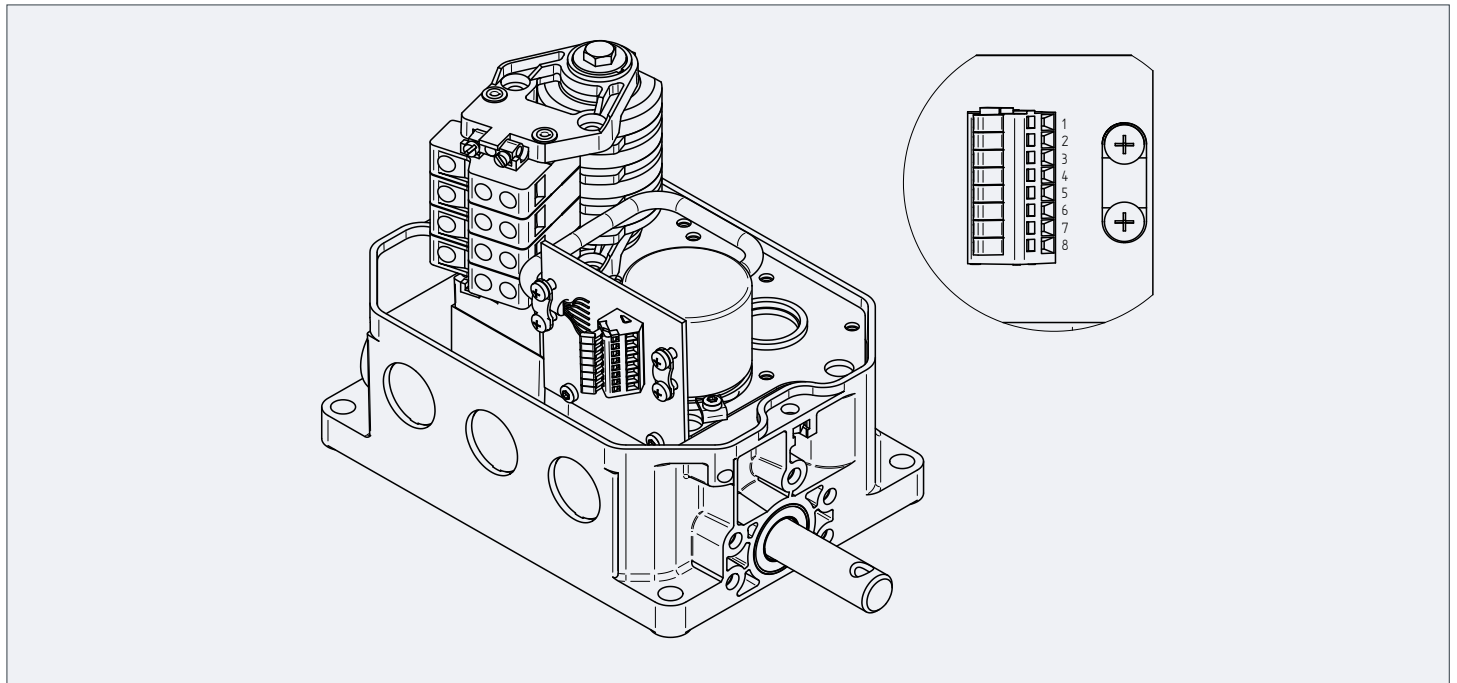

Technical Data	RS422	Push-Pull	Assignment	Pin	Color	Connector	
Power Supply UB	5 V ± 5% or 8...30 V	8 ... 30 V DC	Ground	1	white	Solid conductor	0.08 ... 1.5 mm ² / 28 ... 16 AWG
Pulses / 360°	5 ... 3600		Supply-Voltage V _{cc}	2	brown	Multi-stranded conductor	0.08 ... 1.5 mm ² / 28 ... 16 AWG
Power consumption	Typ. 40 mA	< 40 mA	A - Signal	3	green	Fine-stranded conductor	0.08 ... 1.5 mm ² / 28 ... 16 AWG
(without load)	Max. 90 mA		B - Signal	4	yellow	Strip length	9 ... 9 mm / 0.31 ... 0.35 Inch
Permissible load	± 20 mA	± 50 mA	0 - Signal	5	gray		
Signal level "high"	> 2,5 V	> V _{cc} - 3 V	A-Inv. - Signal	6	pink		
Signal level "low"	< 0,5 V	< 2,5 V	B-Inv. - Signal	7	blue		
Max. Frequency	300 kHz	200 kHz	0-Inv. - Signal	8	red		
Operating Temperature	-40°C ... +85 °C (5...1024 pulses)						
	-30°C ... +85 °C (>1024 pulses)						

Stromag Geared Cam Limit Switches

Limit Switch Control Current

Worm / Bevel Geared Cam Limit Switches

LC[®] / LC[®] M – Option: SSI Multiturn Encoder

Revision number: 3.1.2.14-01

Revision date: 19.11.2019

Features

- Absolute value with high preciseness
- Without gear (Energy harvesting technology)
- Connection via M12 plug at the outside of the housing

Application

- For very high accuracy demands

Additional information

- Driven 1:1 by the bevel gear

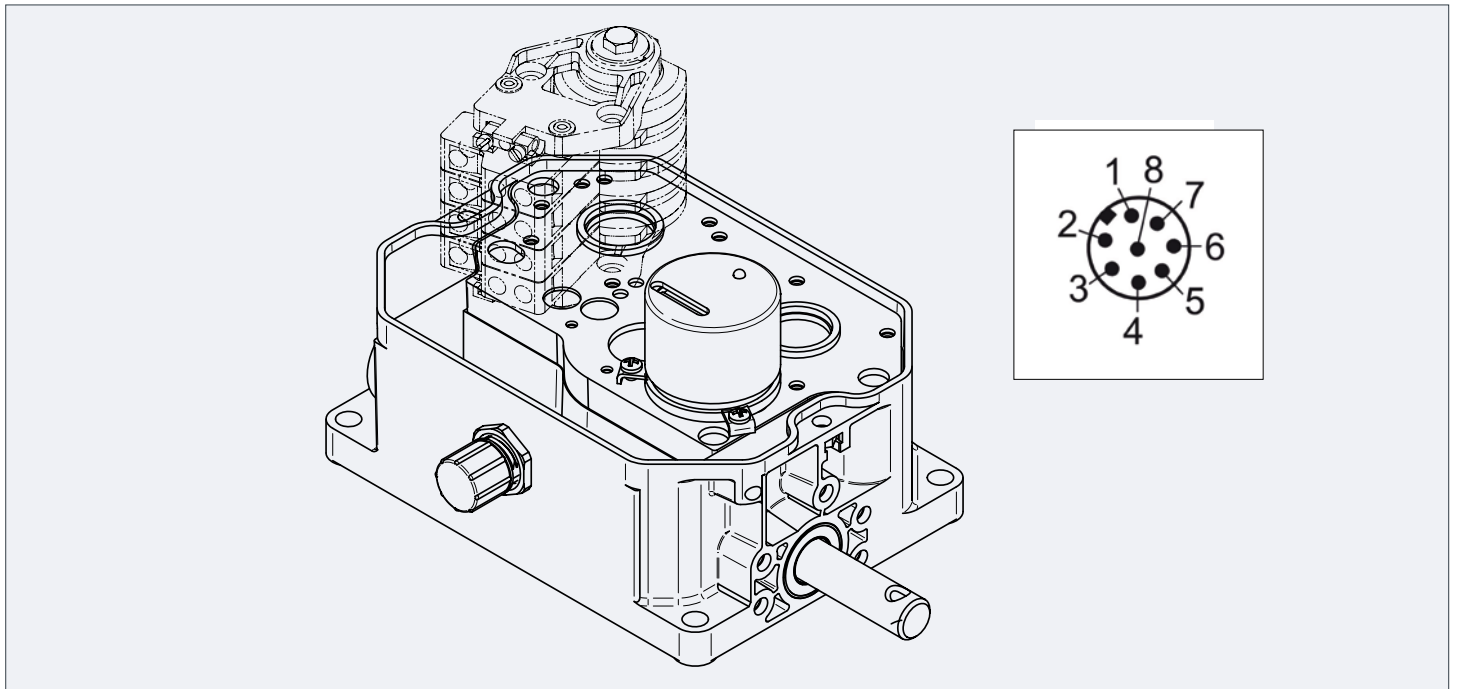

Technical Data		Configuration		Pin Assignment		
Resolution Singleturn	8 ... 14 Bit	Turning direction	CW : DIR = GND	Signal	Pin	Color
Resolution Multiturn	1 ... 39 Bit	(View on shaft)	CCW : DIR = +UB	Ground	1	white
Interface	SSI	Set to Zero	Preset = +UB (2s)	Supply Voltage	2	brown
Code	Gray / Binary	Deactivate	Preset = GND	SSI CLK +	3	green
Clock frequency	100 kHz ... 500 kHz	LED -Behaviour		SSI CLK -	4	yellow
Data output	RS485 comp.	At Boot-Up	red (< 2,3s)	SSI DATA +	5	gray
Power Supply	10 ... 32 V DC	Error	red (> 2,3s)	SSI DATA -	6	pink
Power Consumption	Max. 0,5 W	Normal function	green	Preset	7	blue
Turn on time	max. 1,5 s			DIR	8	red
Operating Temperature	-40°C ... +85 °C			Screen	9	violet

Stromag Geared Cam Limit Switches

Limit Switch Control Current

Worm / Bevel Geared Cam Limit Switches

LC[®] / LC[®] M – Option: CANopen Multiturn Encoder

Revision number: 3.1.2.15-01

Revision date: 19.11.2019

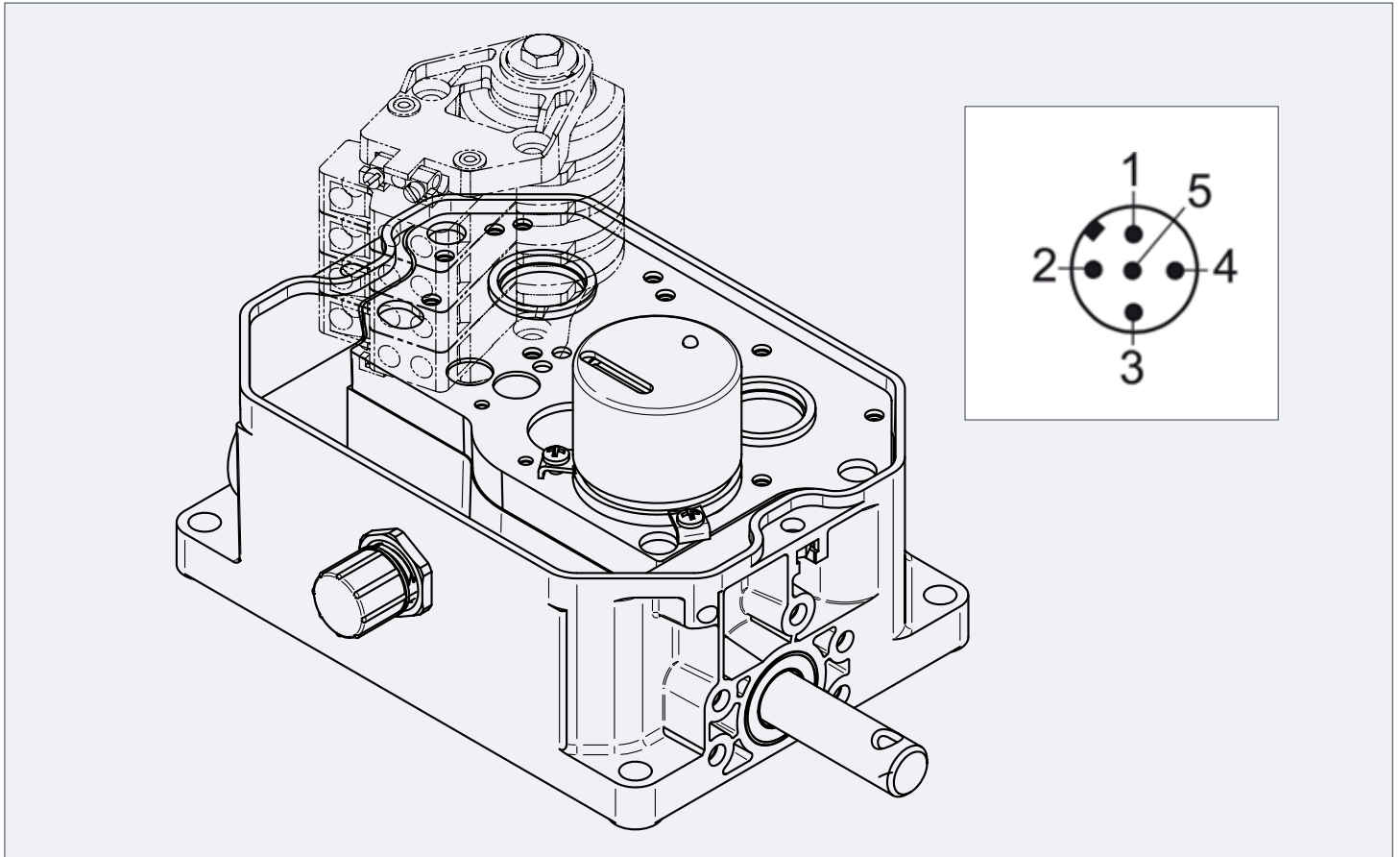

Technical Data	
Resolution singleturn	8 ... 14 Bit
Resolution multiturn	1 ... 39 Bit
Code	Binary
Interface	CAN
Protocol	CANopen
Node ID	1 ... 127 (default: 127)
Programmable CAN transmission modes	Synchronous / Asynchronous
Power Supply	10 ... 32 V DC
Power Consumption	Max. 0,5 W
Turn on time	max. 1,5 s
Operating Temperature	-40°C ... +85 °C

Pin Assignment		
Signal	Pin	Color
Ground	1	white
Supply Voltage	2	brown
SSI CLK +	3	green
SSI CLK -	4	yellow
SSI DATA +	5	gray
SSI DATA -	6	pink
Preset	7	blue
DIR	8	red
Screen	9	violet

Standard settings as well as any customization in the software can be changed via LSS (CiA 305) and the SDO protocol (PDOs, Scaling, Heartbeat, Node-ID, Baud rate, etc.)

Stromag Geared Cam Limit Switches

Limit Switch Control Current

Worm / Bevel Geared Cam Limit Switches

LC[®] / LC[®] M – Option: Internal Profinet Encoder

Revision number: 3.1.2.16-01

Revision date: 19.11.2019

Additional information

- Solution with integrated Profinet encoder inside of the housing
- No additional space outside of the housing required

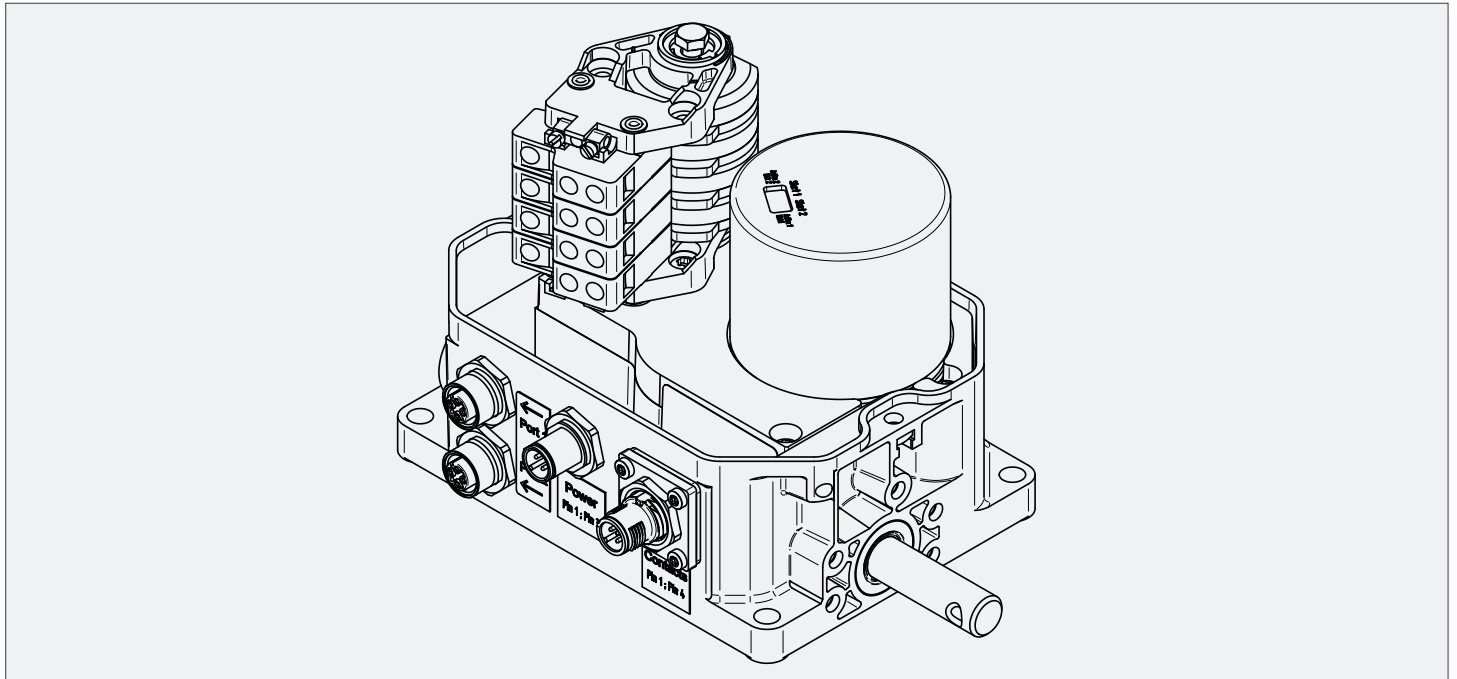

Technical Data	
Sensing principle	magnetic
Resolution Singleturn	up to 16 Bit
Resolution Multiturn	12 Bit
Interface	ProfiNet IO
Output code	binary
Code course	cw / ccw (programmable)
Power Supply	10 ... 30 V DC
Power Consumption	approx. 4 W
Time delay before availability	< 250 ms
Operating Temperature	-40°C ... +70 °C

Pin Assignment		
Signal	Ports 1 & 2	Color
	Female connector M12, 4 pole D-coded	Male connector M12, 4 pole A-coded
1	Tx+	+UB
2	Rx+	n.c.
3	Tx-	GND
4	Rx-	n.c.

Stromag Geared Cam Limit Switches

Limit Switch Control Current

Worm / Bevel Geared Cam Limit Switches

LC[®] / LC[®] M: 2nd shaft end (encoder drive)

Revision number: 3.1.2.17-02

Revision date: 28.10.2022

Additional information

- For driving multiturn hollow shaft encoders from the second shaft end
- Driven 1:1 by the input shaft

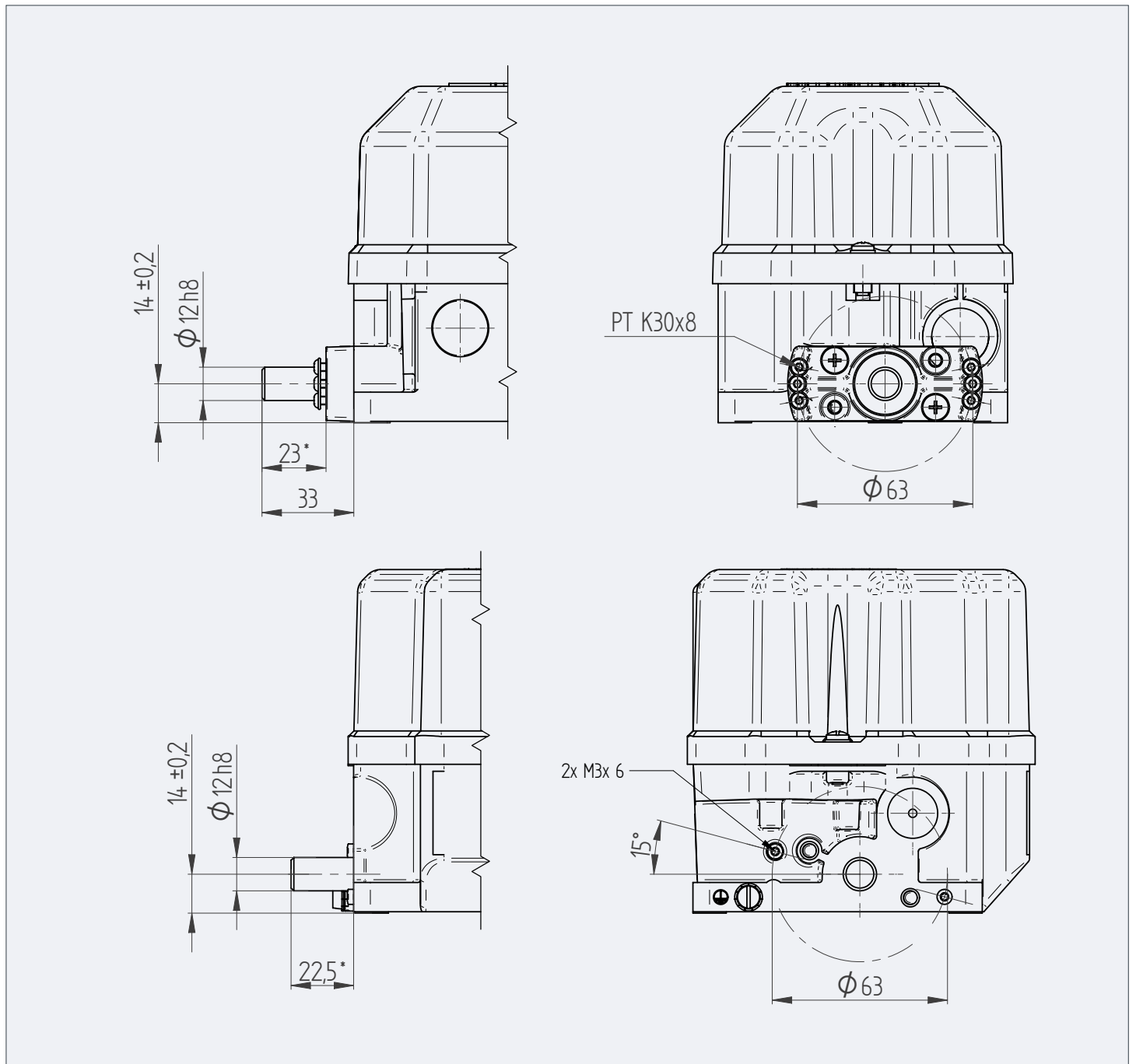

Stromag Geared Cam Limit Switches



Limit Switch Control Current

Worm / Bevel Geared Cam Limit Switches

LC® / LC® M: Key of Types

Revision number: 3.1.2.18-02

Revision date: 12.10.2021

Stromag GmbH Hansastr.120, 59425 Unna Tel.+49(0)2303102-0 Made in Germany 德国制造		 Ui=250VAC Ith=10A
Getriebeendechalter 凸轮开关 Typ 型号 260_LC_499_FV_G Auftr.Nr XXXXXX Nr. XXXX Ref-Nr: XXXXXXXXXX		
IP XX	230VAC/1,5A	60VDC/0,5A
Baujahr XX/XX	GB14048.5 	 E207645 Class2 (For Encoder)

Light Cam® / Light Cam® Metal		Switch type: GCLS Series Light Cam® / Light Cam® Metal	
260	Nominal Revolutions	0.85, 1.85, 3.9, 6, 9, 15, 25, 29, 53, 76, 95, 135, 180, 260, 360, 435, 515, 620, 880	
LC	Housing type	Light Cam®	Synthetic housing
		Light Cam®M	Aluminum housing
4	Number of contacts fitted	1 - 8	
99	Type of switching contact	99	Contact (changeover) with screw connections, contact material: Silver (standard)
		99G	Contact (changeover) with screw connections, contact material: Gold
		99L	Contact (changeover) with soldering pins (for PCB), contact material: Silver
		99P	Contact (changeover) with flat plug connections, contact material: Silver
		99T	Contact (push action) with screw connections, contact material: Silver
		99A	Contact (push action) with screw connections, contact material: Gold
		99B	Contact (changeover) with soldering pins, contact material: Gold
		99C	Contact (changeover) with stranded wire output, contact material: Silver
		90	Contact (NC+NO) with screw connections, contact material: Silver
		90G	Contact (NC+NO) with screw connections, contact material: Gold
88	Contact (2x NC) with screw connections, contact material: Gold		
FV	Type of cam discs	FV	Precise adjustable
G	Additional components	G	With encoder / sensor
		P	With potentiometer

Stromag Geared Cam Limit Switches

Limit Switch Control Current

Worm / Bevel Geared Cam Limit Switches

LC[®] / LC[®] M: Highly customizable solutions

Revision number: 3.1.2.19-01

Revision date: 19.11.2019

Additional information

- Pinion wheels available on request
- Highly customized options for almost all parts available on request

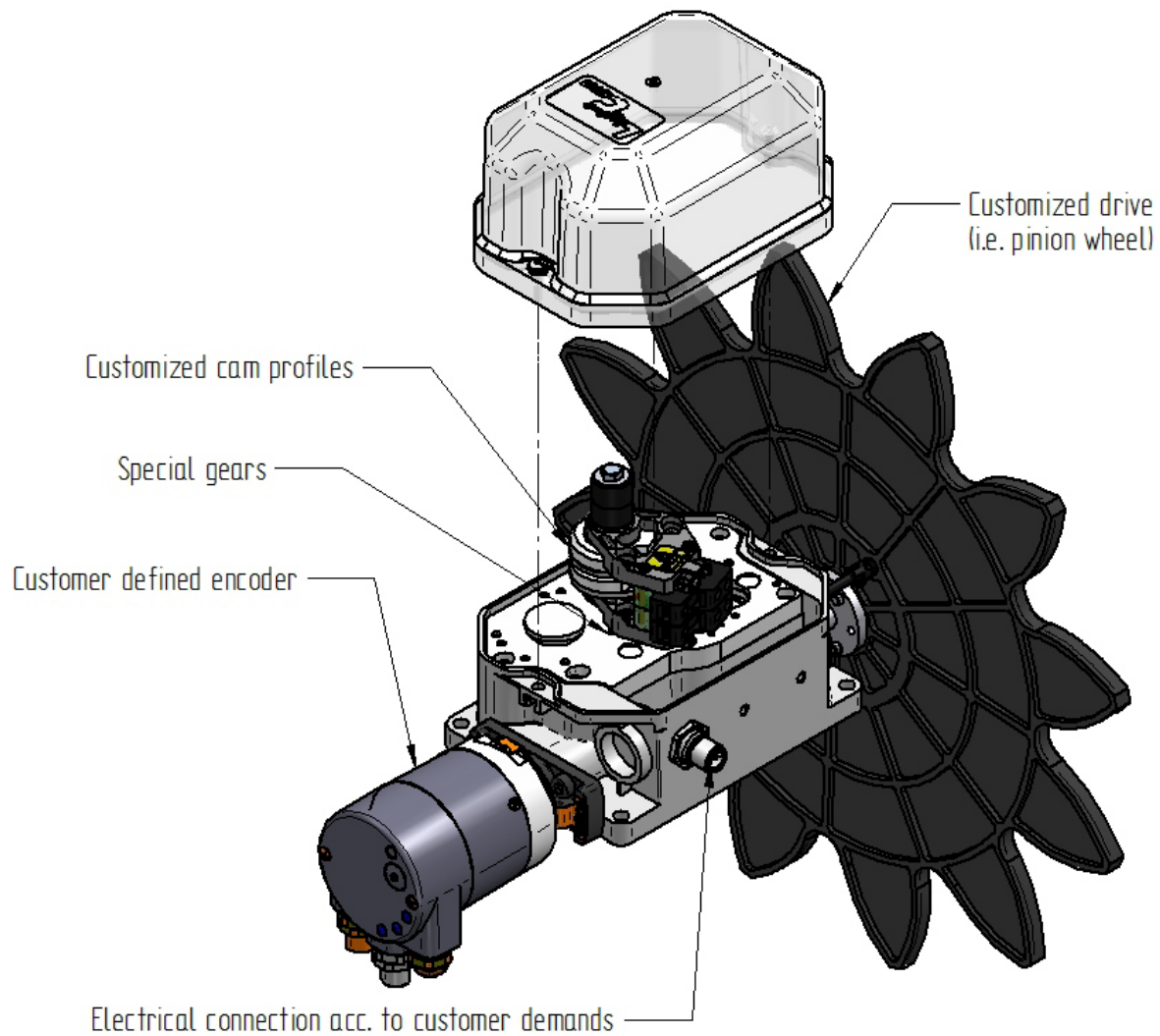

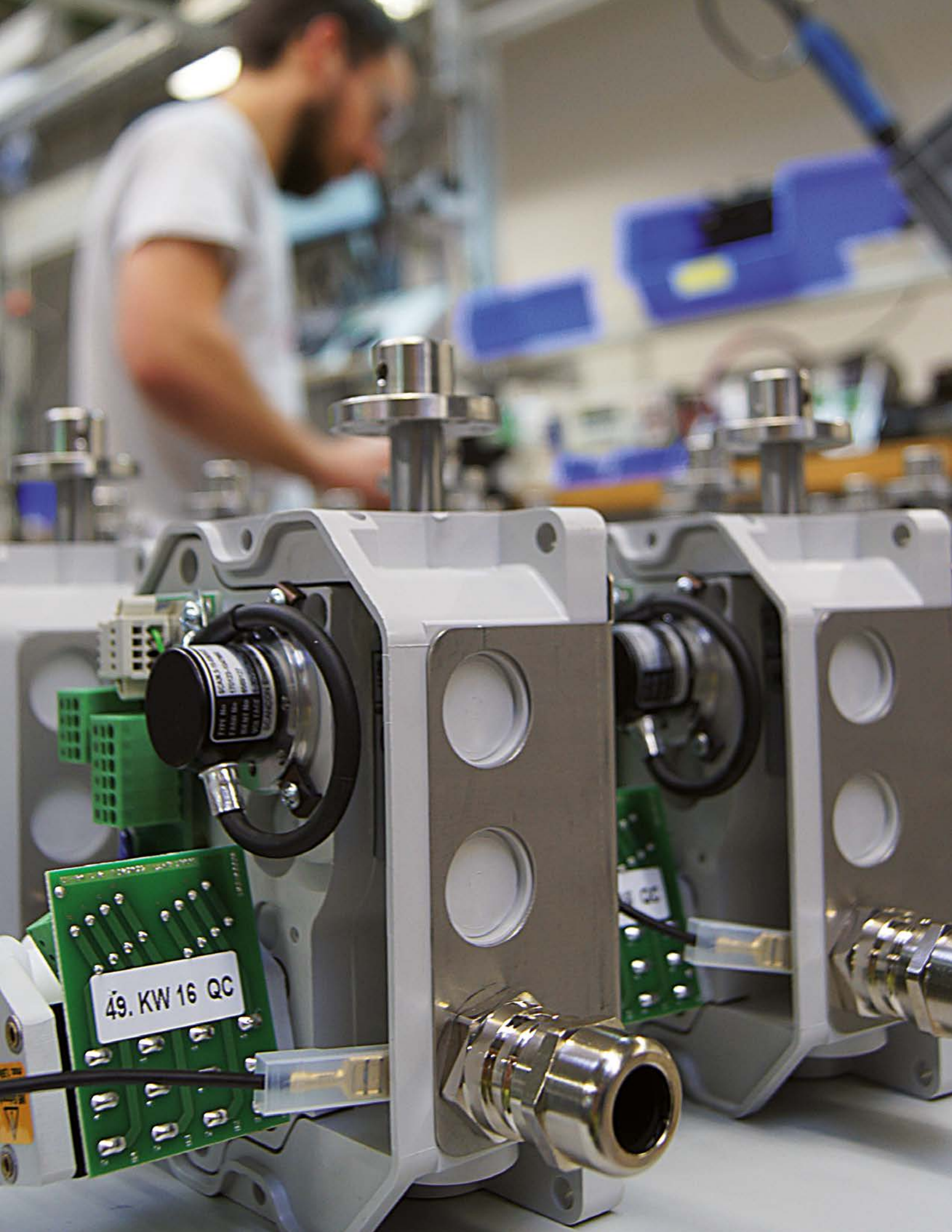

49. KW 16 QC

TYPE No.
PART No.
REV. DATE

Premier Industrial Company Leading Brands

OTHER PRODUCT SOLUTIONS FROM **REGAL REXNORD**

Our comprehensive product offerings include various types of clutches and brakes, overrunning clutches, engineered bearing assemblies, gearing and gear motors along with linear motion products, belted drives, couplings, limit switches, precision motors, drives & controls, and miniature motors. With thousands of product solutions available, Regal Rexnord provides true single source convenience while meeting specific customer requirements. Many major OEMs and end users prefer Regal Rexnord products as their No. 1 choice for performance and reliability.

WWW.REGALREXNORD.COM



Electric Clutches & Brakes

Stromag
Warner Electric



Precision Motors & Automation

Kollmorgen



Heavy Duty Clutches & Brakes

Industrial Clutch
Stromag
Svendborg Brakes
Twiflex
Wichita Clutch



Miniature Motors

Portescap



Overrunning Clutches

Formsprag Clutch
Marland Clutch
Stieber



Linear Systems

Thomson



Engineered Couplings & Universal Joints

Ameridrives
Bibby Turboflex
Guardian Couplings
Huco
Lamiflex Couplings
Stromag
TB Wood's



Specialty Components

Kilian
Stromag
TB Wood's



Gear Drives & Gear Motors

Bauer Gear Motor
Boston Gear
Delroyd Worm Gear
Nuttall Gear



4000 Airline Dr, Suite D Houston,
TX, 77022

Phone: +1-346-398-4400

Email: sales@delreypartners.com