

Evolo 611 Grade A-D

APPLICATION

Optimum vibration isolation for a wide range of applications.
For smaller, light-weighted equipment that needs optimal vibration isolation at both high and low frequencies, such as generator sets, pumps, small diesel engines, compressor units, ventilators, measuring equipment, etc.

MATERIAL

Rubber part: Highest quality natural rubber
Metal: Aluminum

IDENTIFICATION

The type is marked in the mounting plate

ADVANTAGES

- Approved by Lloyd's Register
- Optimum vibration isolation
- Easy and quick installation
- Build in end-limiter to protect against overload
- Capable of handling both vertical and horizontal forces
- Natural rubber gives maximum vibration isolation
- One type fits all weights between 50 and 400 kg
- Stock item.

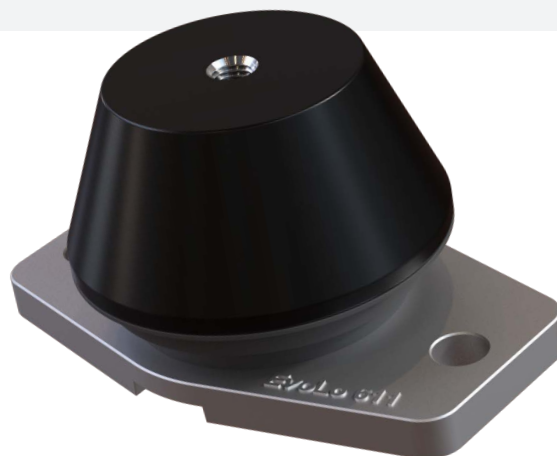

TECHNICAL DRAWING

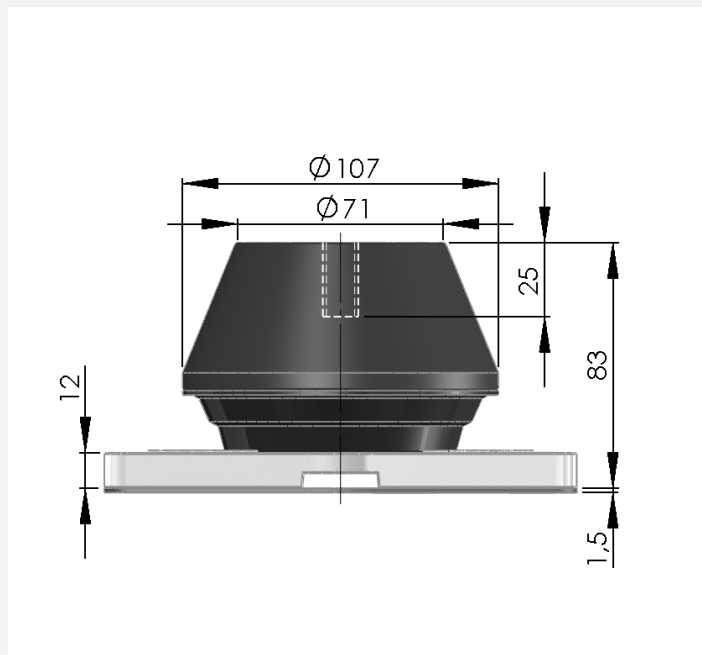
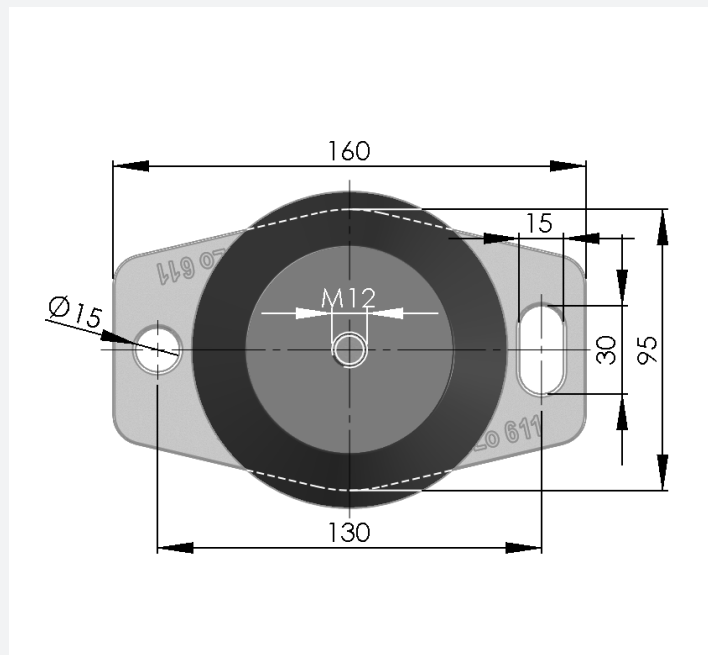

Evolu 611 Grade A-D

TECHNICAL DATA

ARTICLE NO.	GRADE	MAXIMUM LOAD
1030611A0	A	4000 N
1030611B0	B	2750 N
1030611C0	C	1900 N
1030611D0	D	1300 N

STATIC VERTICAL CHARACTERISTICS

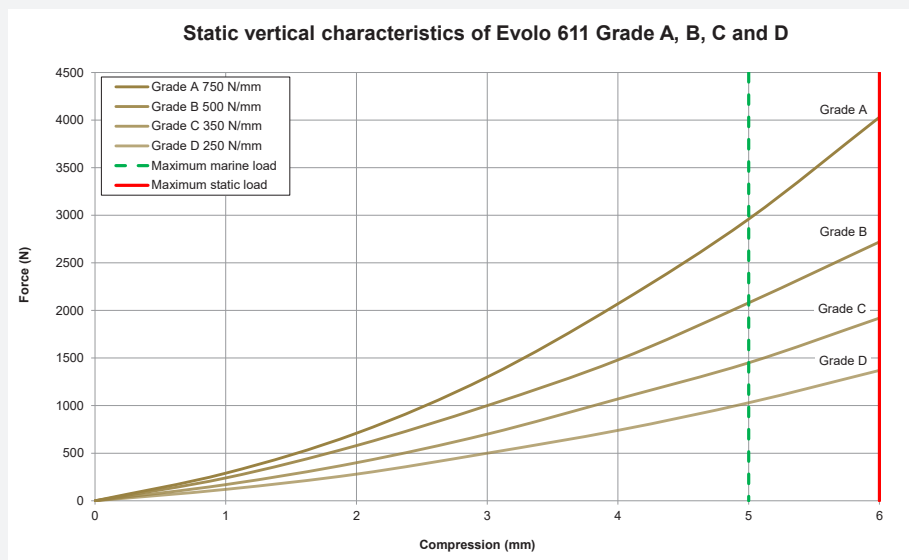

HORIZONTAL CHARACTERISTICS WHEN PRECOMPRESSED 4 MM

