

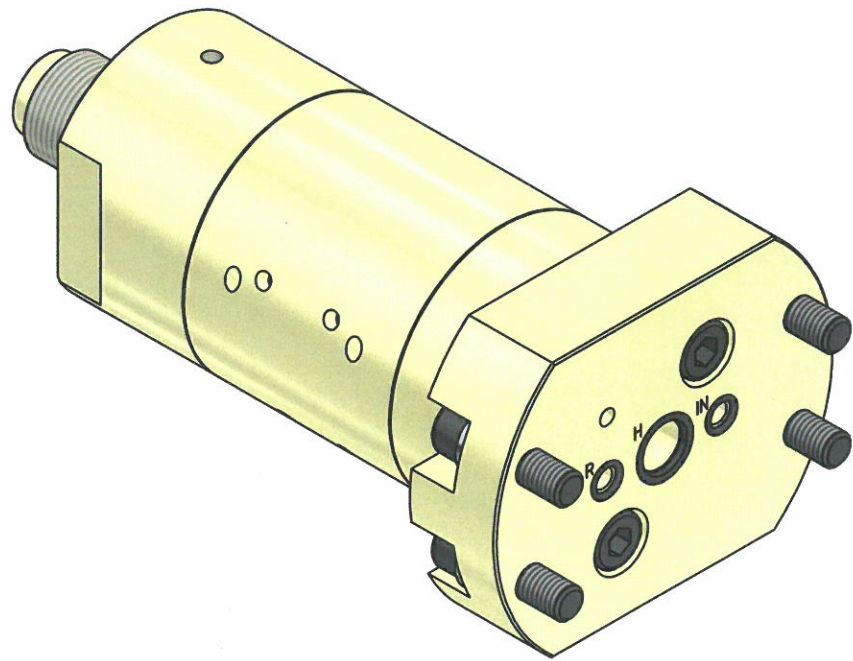

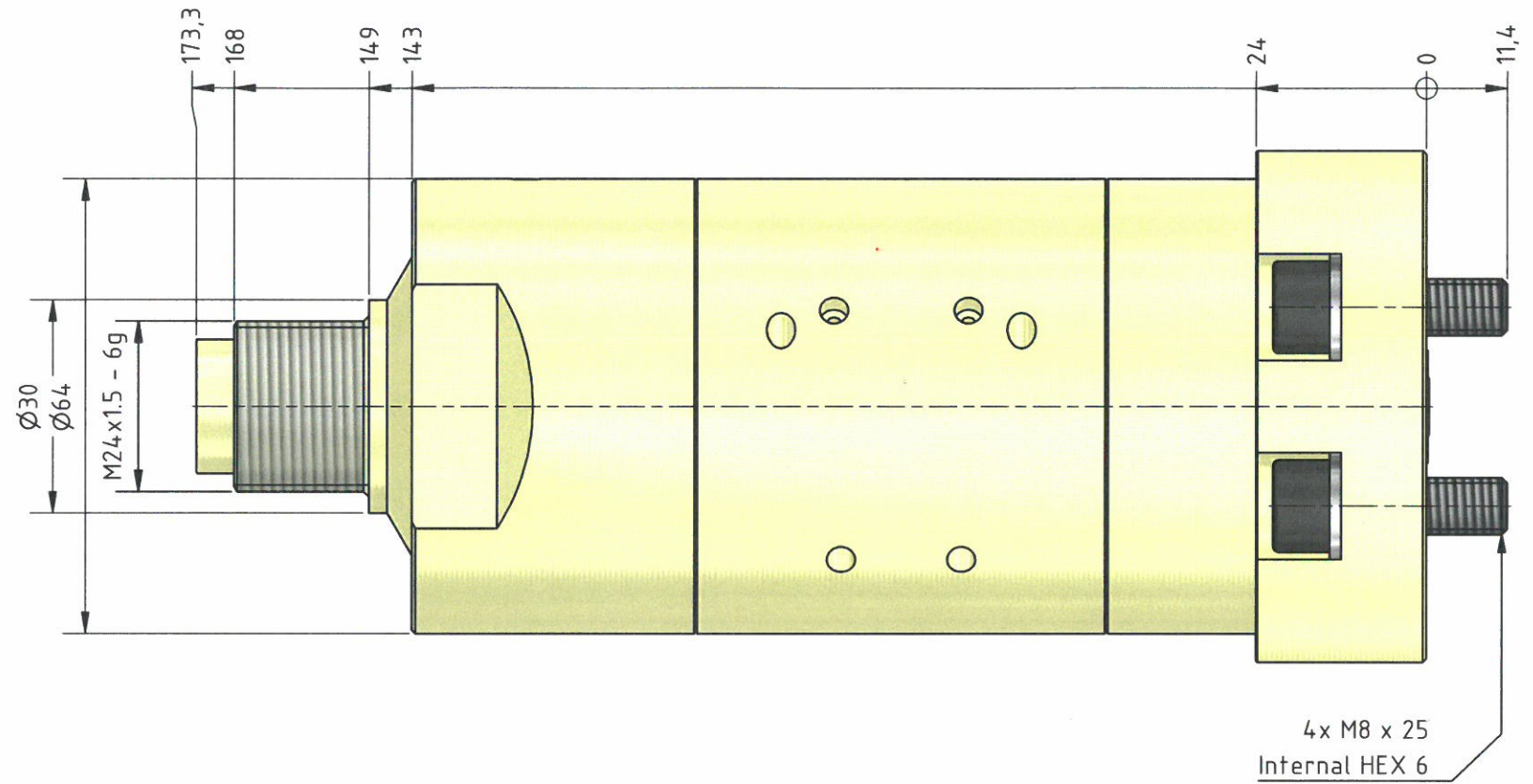

Consumer connections:

IN, R & H: Max. ø6

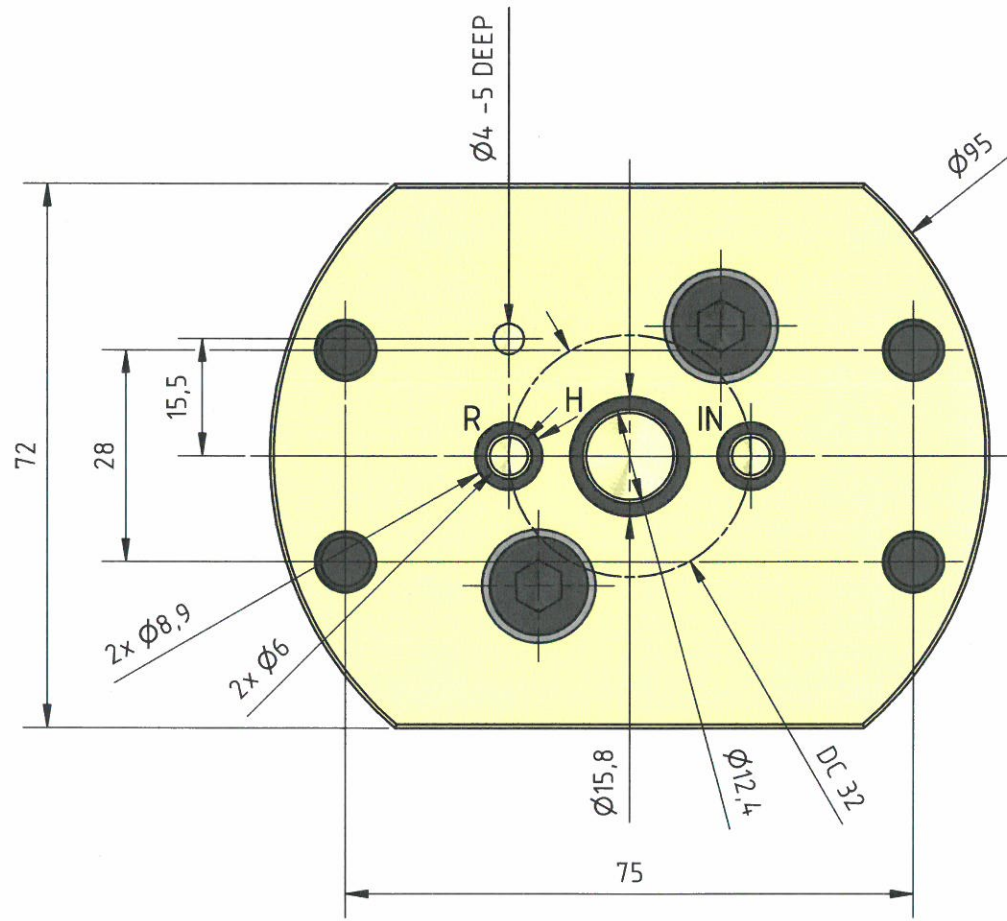

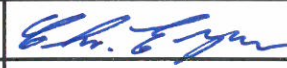
Function diagram: 2D-107-__

Material		Issue	Material Code No.
Changes	Date	Name	Finish
New issue	20.05.08	L.H.	
New issue	05.01.15	L.H.	Break all edges
Drawing renewed with 3D-model. 45° chamfer added.	31.05.16	B.P.	Hardening depth
Consumer connections added.	13.06.2017	B.P.	HV
Designer	Leif Hansen	Scale 1:1	Confidential: Property of miniBOOSTER HYDRAULICS A/S Denmark Not to be handed over to, copied or used by third party. 
Approved by		Format A3	
Date	15.05.08		
		HC2D-__-__-D	
		Hydraulic Booster	
		Assembly Drawing	Drawing No.: 2D-121-05